



ALTERNATOR PRO18S C/4

three-phase brushless synchronous alternator with AVR - 4 poles

Technical Data Sheet

PRO18S C/4

COMMON DATA

Rated Power at 50Hz	kVA	30	
Rated Power at 60Hz	kVA	36	
Rated Power Factor		0.8	
Nominal Temperature	°C	40	
Control System		self excited	
Execution		brushless	
Regulation Type		AVR	
Insulation Class		H	
Protection		IP23	
Maximum Overspeed	rpm	2250	
Overload		110% of rated power for one hour in a cycle of 6 hours	
Air Flow Requirement	m ³ /min	6.9 at 50Hz	7.1 at 60Hz
R.F.I. Suppression		Standard EN55011	

REGULATION DATA

AVR	HVR11	HVR30
Sensing	single-phase	three-phase
Voltage Regulation	±1%	±1%
Sustained Short Circuit	> 250% of rated current	

WINDING DATA

Stator Winding	Double layer with auxiliary winding	
Rotor Winding	with damping cage	
Winding Pitch	2/3	
Number of Leads of Stator	12	
Stator Winding Resistance	0.117 at 20°C	
Rotor Winding Resistance	2.9 at 20°C	
Exciter Stator Resistance	15 at 20°C	
Exciter Rotor Resistance	0.72 at 20°C	
THD at full load	<3%	
THD at no load	<3%	
Excitation at no load	A _{dc}	0.92
Excitation at full load	A _{dc}	2.23

STANDARD

References	EN60034-1 ISO8528-3 EN55011
------------	-----------------------------

PRO18S C/4

ELECTRICAL DATA

Frequency		50Hz - 1500rpm				60Hz - 1800rpm			
Voltage Series Star	V	380/220	400/230	415/240	440/254	415/240	440/254	460/266	480/277
Rated Power in Class H (125°C/40°C)	kVA	30	30	30	25	34	35	36	36
	kW	24	24	24	20	27.2	28	28.8	28.8
Rated Power in Class F (105°C/40°C)	kVA	28	28	28	24	32	33	33.5	33.5
	kW	22.4	22.4	22.4	19.2	25.6	26.4	26.8	26.8
Rated Power Standby (150°C/40°C)	kVA	33	33	32	27.5	36	36.5	38	38
	kW	26.4	26.4	25.6	22	28.8	29.2	30.4	30.4
Rated Power Standby (163°C/27°C)	kVA	34	34	33	28	35	37.5	39	39
	kW	27.2	27.2	26.4	22.4	28	30	31.2	31.2

EFFICIENCY IN CL. H

4/4		87.1%						88.8%
3/4		87.5%						89.3%
2/4		85.0%						87.0%
1/4		81.3%						82.2%

REACTANCES AND TIME CONSTANTS

pcc		0.58						
X _d - dir. axis synchronous		269%	243%	226%	167%	307%	281%	243%
X' _d - dir. axis transient		21.1%	19.0%	17.7%	13.1%	24.0%	22.0%	19.0%
X'' _d - dir. axis subtransient		8.9%	8.0%	7.4%	5.5%	10.1%	9.3%	8.0%
X _q - quad. axis reactance		150%	135%	125%	93%	171%	156%	135%
T' _{do} - O.C. field time constant		125ms						
T' _d - Transient time constant		10ms						
T'' _d - Sub-transient time constant		5ms						

MECHANICAL DATA

Bearing non drive end			6307-2RS-C3
Bearing drive end (B3/B14 form)			6309-2RS-C3
Weight of generator	in B2	kg	150
	in B3/B14	kg	153.5
	in B3/B9	kg	\

PRO18S C/4

MOMENT OF INERZIA

B3/B9	kg·m ²	\
SAE 7½	kg·m ²	0.281
SAE 8	kg·m ²	0.29
SAE 10	kg·m ²	0.306
SAE 11½	kg·m ²	0.326
SAE 14	kg·m ²	\
SAE 18	kg·m ²	\
B3/B14	kg·m ²	0.272

POWER VARIATION ACCORDING TO TEMPERATURE AND ALTITUDE

Altitude	Ambient temperature				
	25°C	40°C	45°C	50°C	55°C
< 1000m	1.09	1	0.96	0.93	0.91
1000m - 1500m	1.01	0.96	0.92	0.89	0.87
1500m - 2000m	0.96	0.91	0.87	0.84	0.83
2000m - 3000m	0.9	0.85	0.81	0.78	0.76

WIRING DIAGRAM

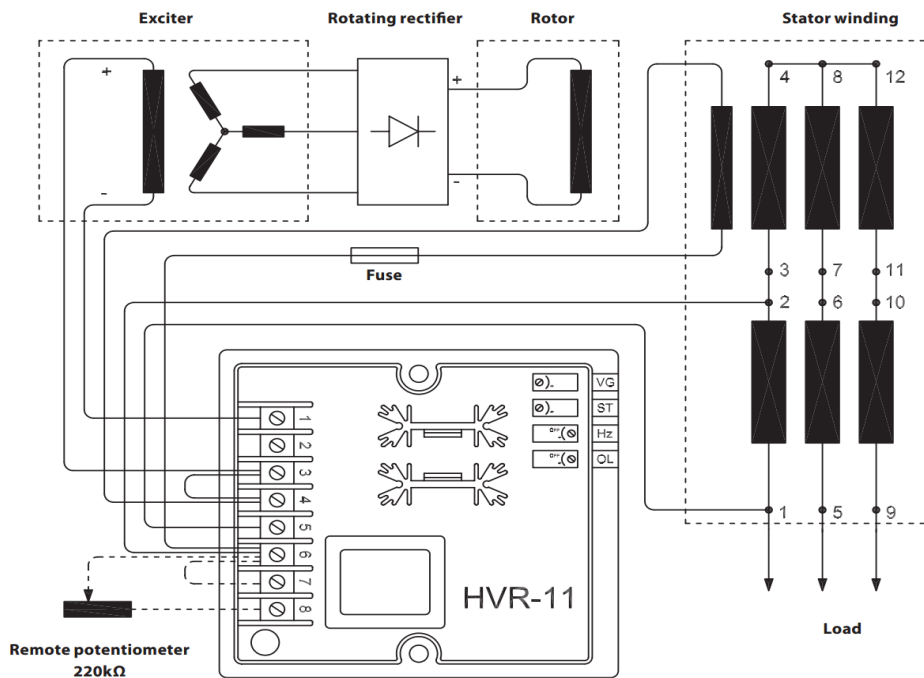

PRO18S C/4

TRANSIENT VOLTAGE VARIATION 50Hz

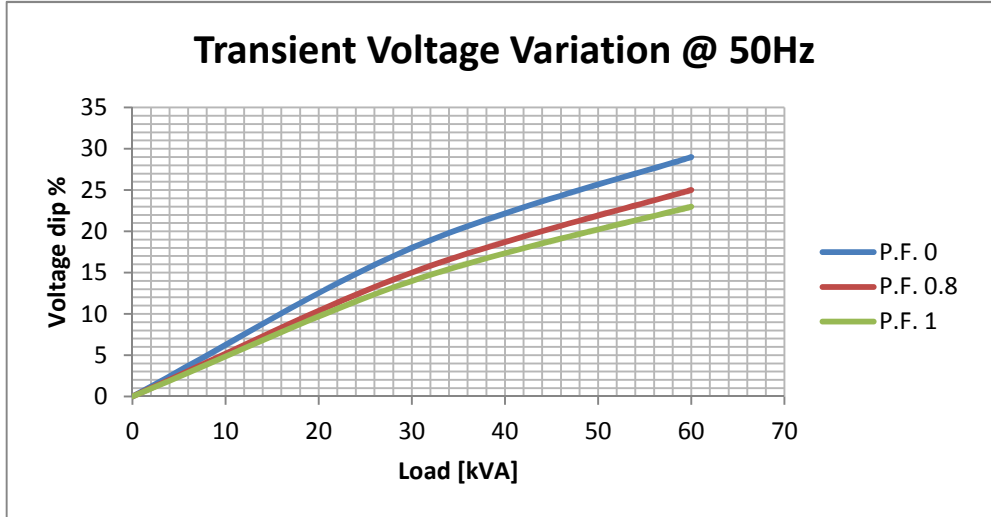

TRANSIENT VOLTAGE VARIATION 60Hz

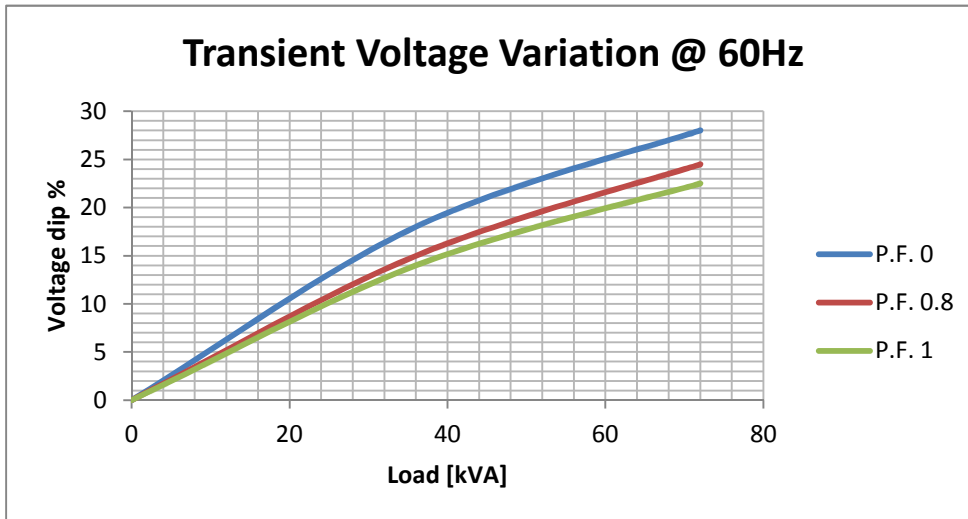

PRO18S C/4

EFFICIENCY 50Hz

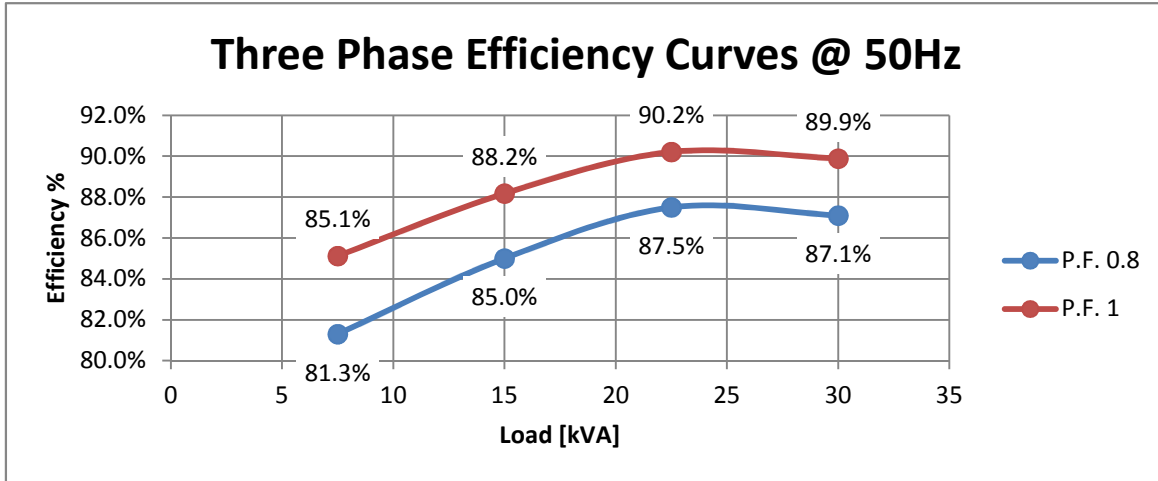

EFFICIENCY 60Hz

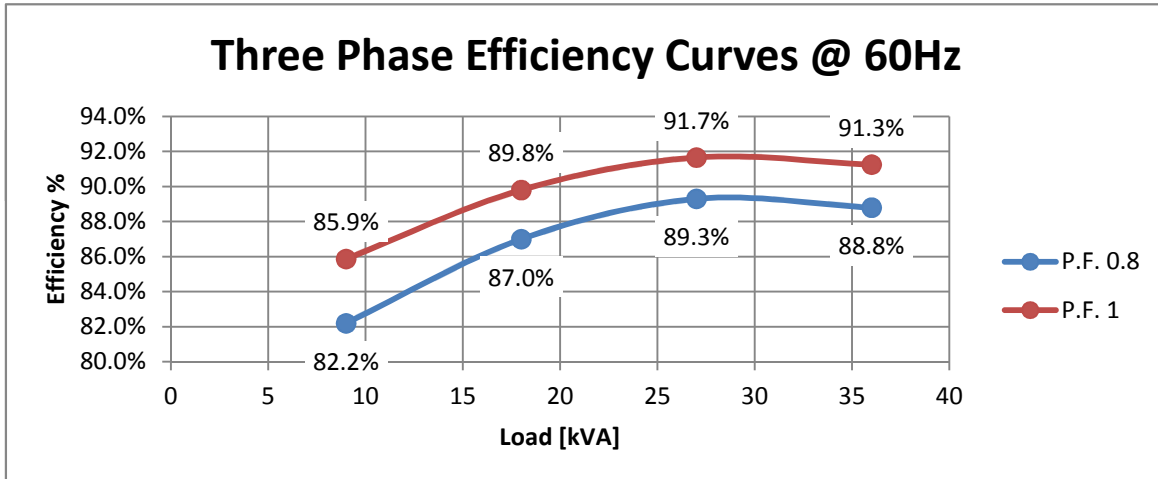

PRO18S C/4

FORMA - FORM B3/B14

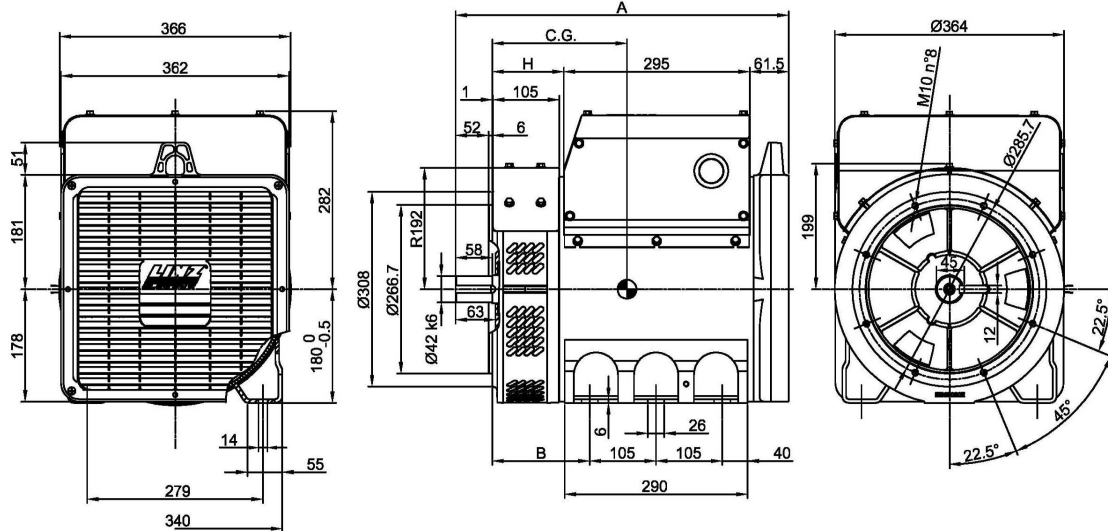

FORMA - FORM MD35

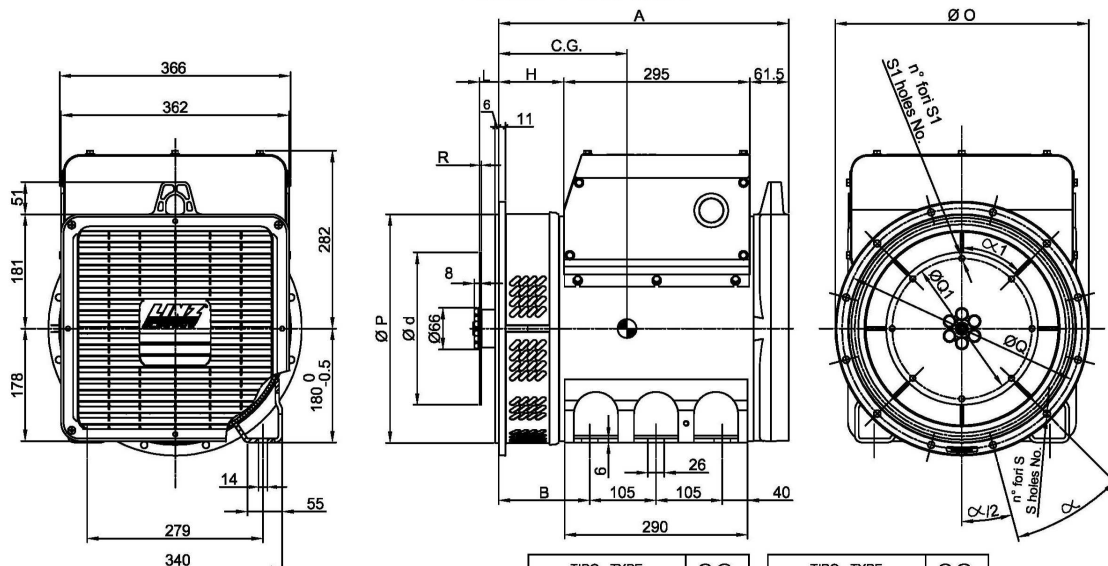

FORMA - FORM		A	B	H
B3/B14	PRO 18S	528	155	113.5
	PRO 18M	598		183.5
	PRO 18L	710	260	295.5
MD35	PRO 18S	460	145	103.5
	PRO 18M	530		173.5
	PRO 18L	642	250	285.5

TIPO - TYPE	C.G.	TIPO - TYPE	C.G.
PRO18S A/4 B3/B14	217	PRO18S A/4 MD35	213
PRO18S B/4 B3/B14	221	PRO18S B/4 MD35	217
PRO18S C/4 B3/B14	228	PRO18S C/4 MD35	223
PRO18M D/4 B3/B14	251	PRO18M D/4 MD35	246
PRO18M E/4 B3/B14	262	PRO18M E/4 MD35	257
PRO18L F/4 B3/B14	301	PRO18L F/4 MD35	296
PRO18L G/4 B3/B14	318	PRO18L G/4 MD35	313

SAE N.	FLANGIE - FLANGES - BRIDAS					
	Ø O	Ø P	Ø Q	n. fori holes No.	S	α
5	356	314.3	333.4	8	11	45°
4	402	362	381	12		30°
3	451	409.6	428.6	12		30°
2	490	447.7	466.7	12		30°
						30°

SAE N.	GIUNTI A DISCO - COUPLING DISCS - JUNTAS A DISCOS						
	L	Ø d	Ø Q1	n. fori holes No.	S1	α1	R
6 1/2	30.2	215.9	200	6	9	60°	3
7 1/2	30.2	241.3	222.25	8	9	45°	
8	62	263.52	244.47	6	10.5	60	
10	53.8	314.32	295.27	8	10.5	45°	
11 1/2	39.6	352.42	333.37	8	10.5	45°	