



## **ALTERNATOR PRO22M E/4**

*three-phase brushless synchronous alternator with AVR - 4 poles*

Technical Data Sheet

## PRO22M E/4

### COMMON DATA

Rated Power at 50Hz	kVA	130	
Rated Power at 60Hz	kVA	156	
Rated Power Factor		0.8	
Nominal Temperature	°C	40	
Control System		self excited	
Execution		brushless	
Regulation Type		AVR	
Insulation Class		H	
Protection		IP23	
Maximum Overspeed	rpm	2250	
Overload		110% of rated power for one hour in a cycle of 6 hours	
Air Flow Requirement	m <sup>3</sup> /min	18.2 at 50Hz	21.2 at 60Hz
R.F.I. Suppression		Standard EN55011	

### REGULATION DATA

AVR	HVR11	HVR30
Sensing	single-phase	three-phase
Voltage Regulation	±1%	±1%
Sustained Short Circuit	> 250% of rated current	

### WINDING DATA

Stator Winding	Double layer with auxiliary winding	
Rotor Winding	with damping cage	
Winding Pitch	2/3	
Number of Leads of Stator	12	
Stator Winding Resistance	0.014 at 20°C	
Rotor Winding Resistance	3.95 at 20°C	
Exciter Stator Resistance	14.3 at 20°C	
Exciter Rotor Resistance	0.47 at 20°C	
THD at full load	<3%	
THD at no load	<3%	
Excitation at no load	A <sub>dc</sub>	0.75
Excitation at full load	A <sub>dc</sub>	2.5

### STANDARD

References	EN60034-1 ISO8528-3 EN55011
------------	-----------------------------

## PRO22M E/4

### ELECTRICAL DATA

Frequency		50Hz - 1500rpm				60Hz - 1800rpm			
Voltage Series Star	V	<b>380/220</b>	<b>400/230</b>	<b>415/240</b>	<b>440/254</b>	<b>415/240</b>	<b>440/254</b>	<b>460/266</b>	<b>480/277</b>
Rated Power in Class H (125°C/40°C)	kVA	130	130	130	110	139	150	156	156
	kW	104	104	104	88	111.2	120	124.8	124.8
Rated Power in Class F (105°C/40°C)	kVA	121	121	121	100	129	139	145	145
	kW	96.8	96.8	96.8	80	103.2	111.2	116	116
Rated Power Standby (150°C/40°C)	kVA	142	142	140	116	148	160	167	167
	kW	113.6	113.6	112	92.8	118.4	128	133.6	133.6
Rated Power Standby (163°C/27°C)	kVA	147	147	145	119	157	169	176	176
	kW	117.6	117.6	116	95.2	125.6	135.2	140.8	140.8

### EFFICIENCY IN CL. H

4/4		92.3%						92.5%
3/4		92.5%						92.7%
2/4		90.7%						91.4%
1/4		88.2%						89.6%

### REACTANCES AND TIME CONSTANTS

pcc		0.45							
X <sub>d</sub> - dir. axis synchronous		327%	295%	274%	206%	352%	338%	321%	295%
X' <sub>d</sub> - dir. axis transient		21.1%	19.0%	17.7%	13.3%	22.6%	21.7%	20.7%	19.0%
X'' <sub>d</sub> - dir. axis subtransient		9.4%	8.5%	7.9%	5.9%	10.1%	9.7%	9.3%	8.5%
X <sub>q</sub> - quad. axis reactance		216%	195%	181%	136%	232%	223%	212%	195%
T' <sub>do</sub> - O.C. field time constant		298ms							
T' <sub>d</sub> - Transient time constant		23ms							
T'' <sub>d</sub> - Sub-transient time constant		10ms							

### MECHANICAL DATA

Bearing non drive end				6309-2RS-C3
Bearing drive end (B3/B14 form)				6314-2RS-C3
Weight of generator	in B2	kg		454
	in B3/B14	kg		456
	in B3/B9	kg		\

# PRO22M E/4

## MOMENT OF INERZIA

B3/B9	kg·m <sup>2</sup>	\
SAE 7½	kg·m <sup>2</sup>	\
SAE 8	kg·m <sup>2</sup>	\
SAE 10	kg·m <sup>2</sup>	\
SAE 11½	kg·m <sup>2</sup>	1.308
SAE 14	kg·m <sup>2</sup>	1.456
SAE 18	kg·m <sup>2</sup>	\
B3/B14	kg·m <sup>2</sup>	1.23

## POWER VARIATION ACCORDING TO TEMPERATURE AND ALTITUDE

Altitude	Ambient temperature				
	25°C	40°C	45°C	50°C	55°C
< 1000m	1.09	1	0.96	0.93	0.91
1000m - 1500m	1.01	0.96	0.92	0.89	0.87
1500m - 2000m	0.96	0.91	0.87	0.84	0.83
2000m - 3000m	0.9	0.85	0.81	0.78	0.76

## WIRING DIAGRAM

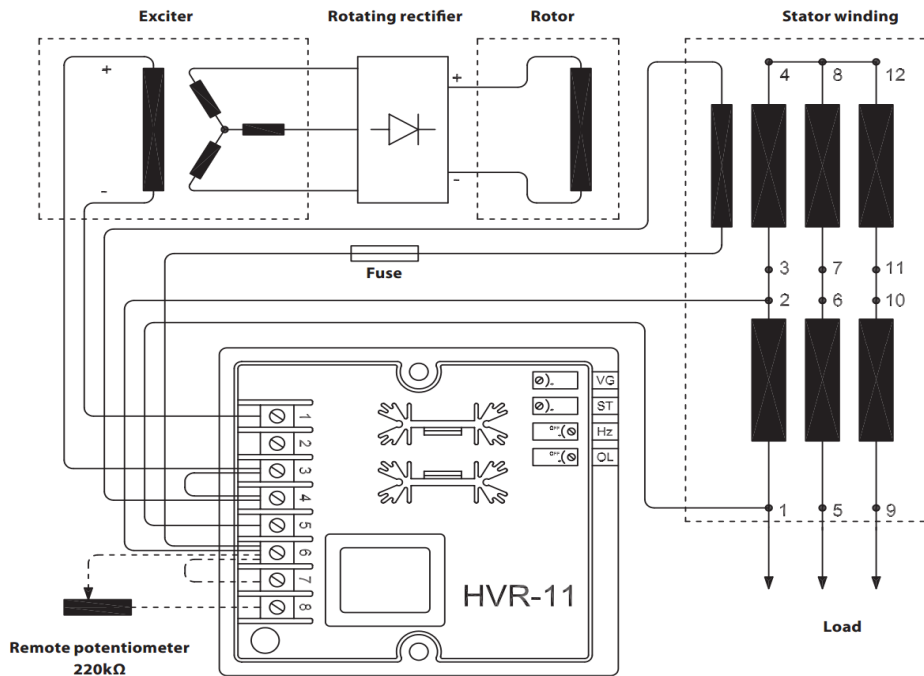

**PRO22M E/4**

**TRANSIENT VOLTAGE VARIATION 50Hz**

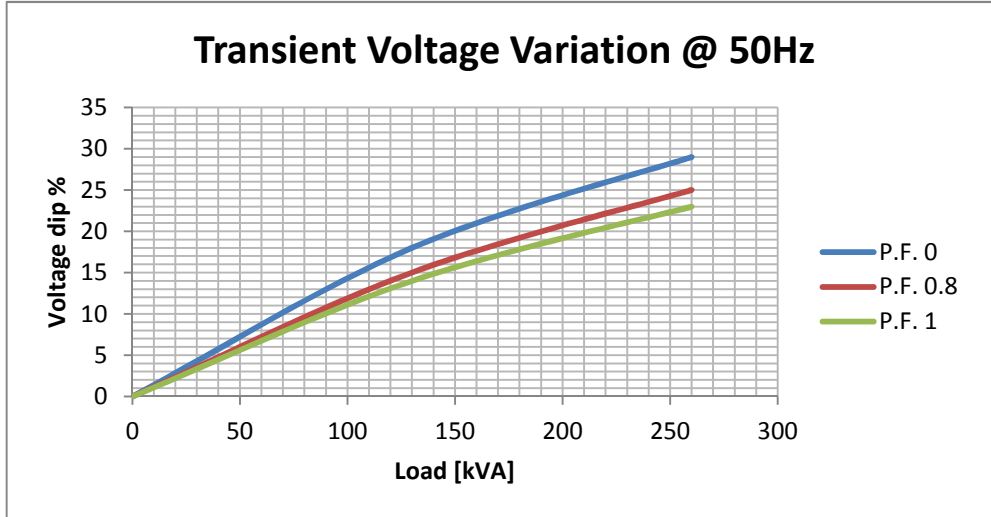

**TRANSIENT VOLTAGE VARIATION 60Hz**

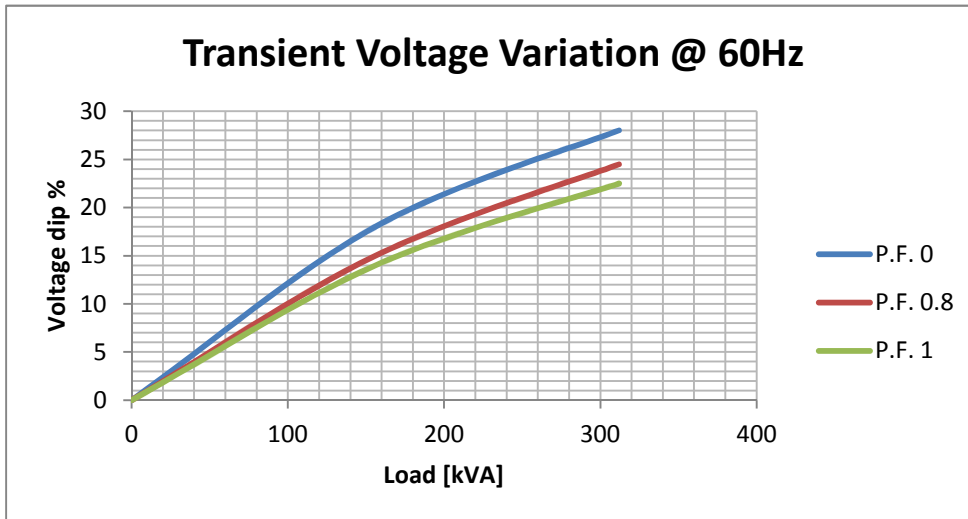

**PRO22M E/4**

**EFFICIENCY 50Hz**

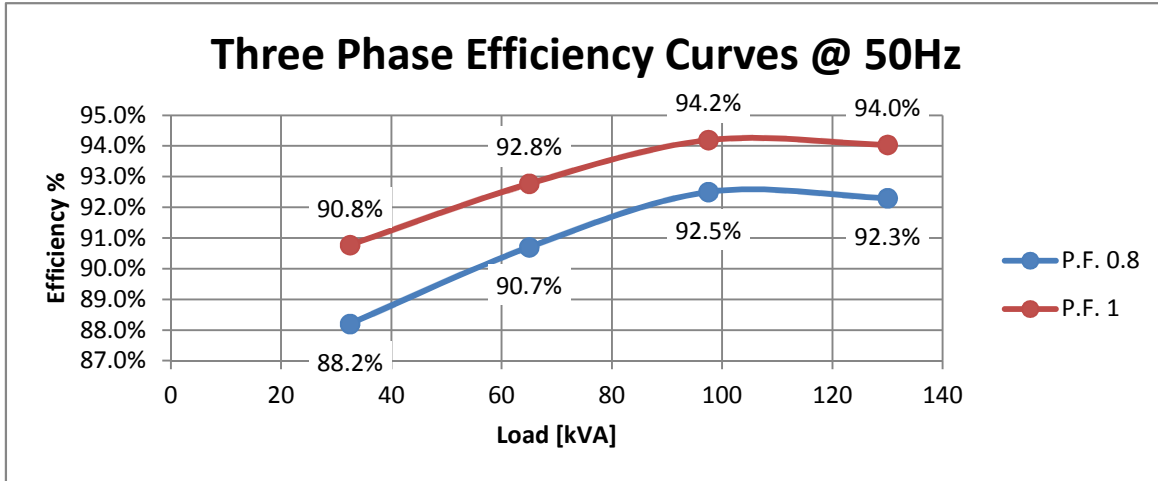

**EFFICIENCY 60Hz**

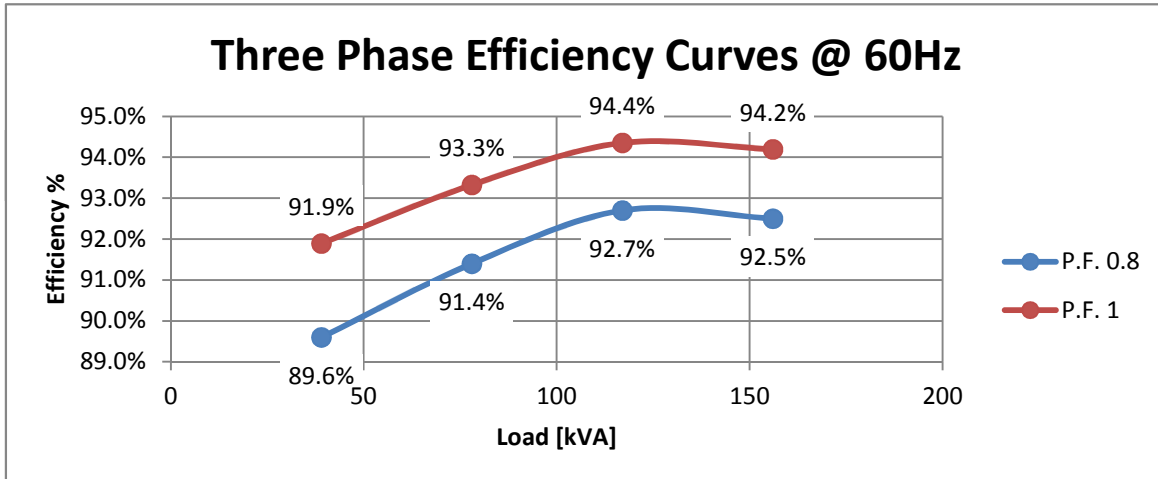

# PRO22M E/4

**FORMA - FORM B3/B14**

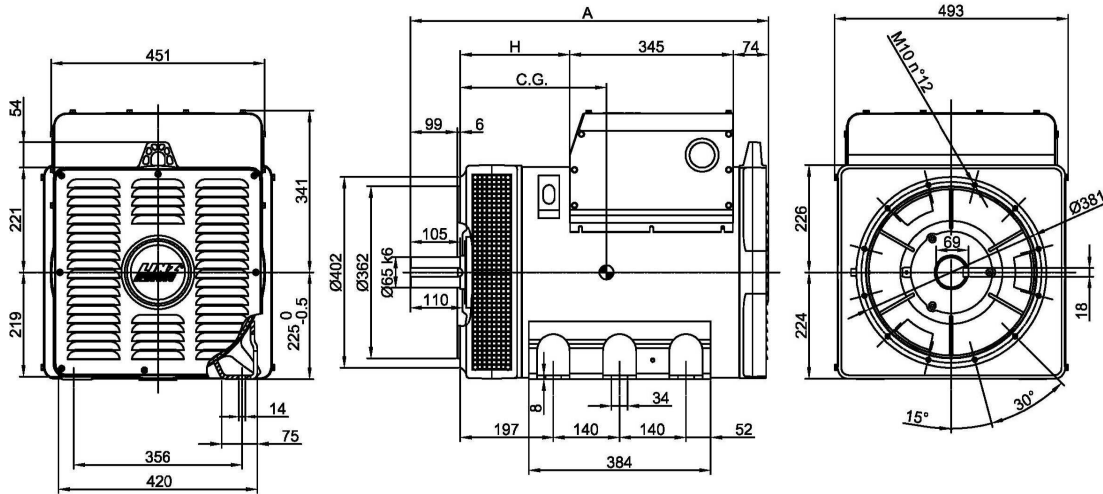

**FORMA - FORM SAE**

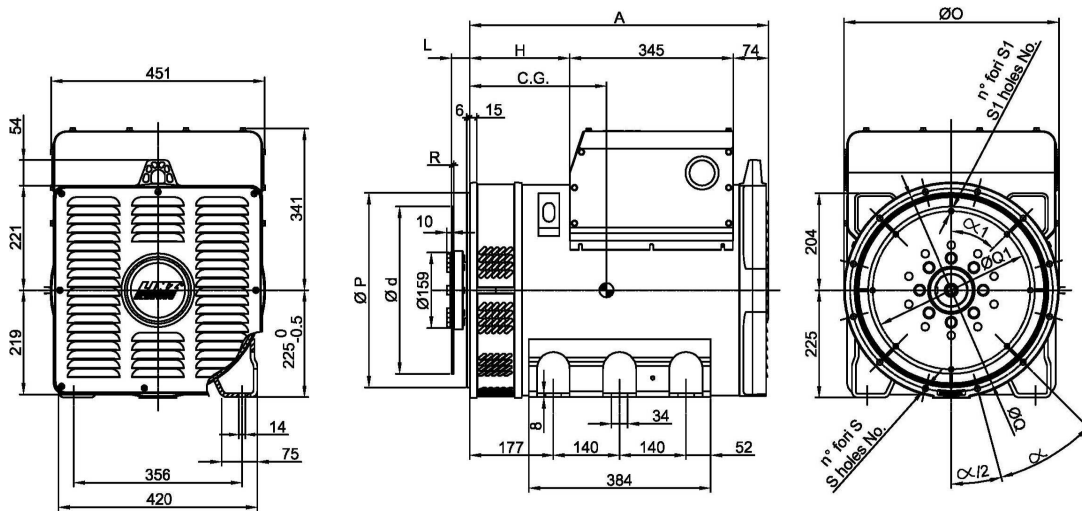

FORMA - FORM		A	H
B3/B14	PRO 22S	756	232
	PRO 22M	886	362
SAE	PRO 22S	631	212
	PRO 22M	761	342

TIPO - TYPE	C.G.
PRO22S A/4 B3/B14	284
PRO22S B/4 B3/B14	293
PRO22S C/4 B3/B14	299
PRO22S D/4 B3/B14	313
PRO22M E/4 B3/B14	359
PRO22M F/4 B3/B14	377

TIPO - TYPE	C.G.
PRO22S A/4 SAE	270
PRO22S B/4 SAE	279
PRO22S C/4 SAE	285
PRO22S D/4 SAE	298
PRO22M E/4 SAE	344
PRO22M F/4 SAE	362

SAE N.	FLANGIE - FLANGES - BRIDAS					
	Ø O	Ø P	Ø Q	n. fori holes No.	S	α
3	454	409.6	428.6	12	12	30°
2	492	447.68	466.7			
1	552	511.18	530.2			

SAE N.	GIUNTI A DISCO - COUPLING DISCS - JUNTAS A DISCOS						
	L	Ø d	Ø Q1	n. fori holes No.	S1	α1	R
11 1/2	39.6	352.42	333.37	8	10.5	45°	6
14	25.4	466.72	438.15	8	14	45°	