



Low Voltage Alternators - 4 pole

TAL040 - TAL042 - TAL044

Electrical and mechanical data

Three phase

10 to 165 kVA - 50 Hz / 12.5 to 206 kVA - 60 Hz

Single phase

10.5 to 82 kVA - 50 Hz / 11.5 to 125 kVA - 60 Hz

Leroy-Somer[™]

Low Voltage Alternators - 4 pole

TAL040 - TAL042 - TAL044 Three phase 10 to 165 kVA - 50 Hz / 12.5 to 206 kVA - 60 Hz

Adapted to needs

The TAL alternator range is designed to meet the specific needs of telecommunications, commercial & industrial markets, as well as stand-by and prime power applications.



Compliant with international standards

The TAL range complies with international standards and regulations: IEC 60034 and derivative. The range is designed, manufactured and marketed in an ISO 9001 and 14001 environment.

Electrical design

- Class H insulation
- Low voltage winding
- 4 - terminal plates
- Optimized performance

Robust design

- Compact and rugged assembly to withstand engine vibrations
- Steel frame
- Aluminum flanges and shields
- Single-bearing design to be suitable with most diesel engines
- Sealed for life single bearing
- Direction of rotation: clockwise



Excitation and regulation

- The TAL range is shunt excited
- R120 voltage regulator is integrated into the terminal box

Compact terminal box

- Easy access to AVR and terminals

Environment and protection

- The alternator is IP 23
- Standard winding protection for non-harsh environment with relative humidity $\leq 95\%$

Available options

- Customized painting
- Space heater
- Flying leads with small terminal box
- Winding protection for harsh environments and relative humidity greater than 95% : possible derating ratio according to the following table

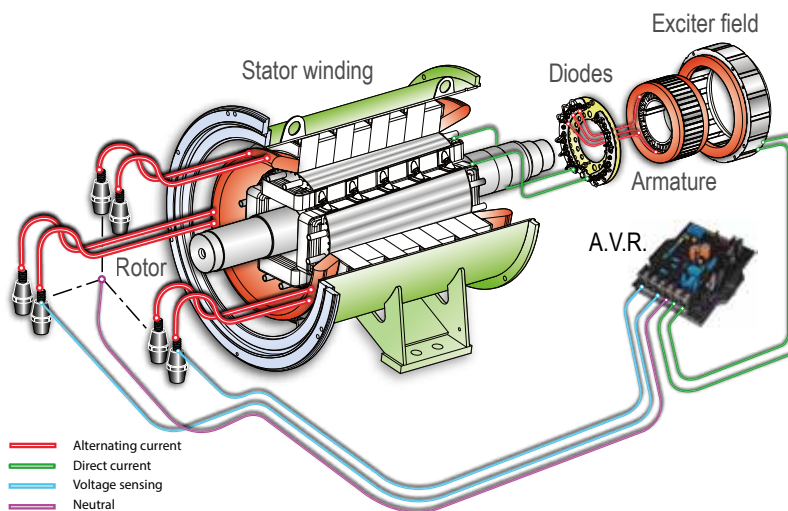

	50 Hz			60 Hz
Type	380 V	400 V	415 V	All voltages
TAL040	1	1	1	1
TAL042	0.97	1 except 0.97 for TAL042 G & H	1 except 0.97 for TAL042 G & H	1 except 0.97 for TAL042 G & H
TAL044	1 except 0.97 for TAL044 K	1 except 0.97 for TAL044 K	1 except 0.97 for TAL044 K	1 except 0.97 for TAL044 K

Low Voltage Alternators - 4 pole

TAL040 - TAL042 - TAL044 Three phase 10 to 165 kVA - 50 Hz / 12.5 to 206 kVA - 60 Hz

General characteristics - 3 phase

Insulation class	H	Excitation system	SHUNT
Winding pitch	2/3 (Winding 6S)	AVR type	R120
Number of wires	6	Voltage regulation (*)	± 1 %
Protection	IP 23	Totale Harmonic distortion THD (**) in no-load:	< 3.5 % according to C.E.I.
Altitude	≤ 1000 m	Totale Harmonic distortion THD (**) in linear load:	< 5 % according to C.E.I.
Overspeed	2250 R.P.M.	Waveform: NEMA = TIF (**)	< 50
Air flow (m³/s)	50Hz : TAL040 : 0.06 - TAL042 : 0.10 - TAL044 : 0.30 60Hz : TAL040 : 0.07 - TAL042 : 0.13 - TAL044 : 0.35	(*) Steady state. (**) between phases	

Ratings - 3 phase

kVA / kW - P.F. = 0.8																
Type	50 Hz - 1500 R.P.M.								60 Hz - 1800 R.P.M.							
Duty/T°C	Continuous / 40°C				Stand-by / 27°C				Continuous / 40°C				Stand-by / 27°C			
Class/T°K	H / 125°K				H / 163°K				H / 125°K				H / 163°K			
	Rating kVA				Rating kVA				Rating kVA				Rating kVA			
Phase	3 ph.		1 ph.		3 ph.		1 ph.		3 ph.		1 ph.		3 ph.		1 ph.	
Y	380V	400V	415V		380V	400V	415V		380V	416V	440V	480V	380V	416V	440V	480V
Δ	220V	230V	240V	230V	220V	230V	240V	230V	220V	240V	254V	277V	220V	240V	254V	277V
TAL040 B	10	10	10	7	11	11	11	8	10	11	11.5	12.5	11.5	12	13	14
TAL040 C	12.5	12.5	12.5	7	14	14	14	8	12.5	13.5	14.5	15.5	14	15	16	17
TAL040 D	15	15	15	10.5	16.5	16.5	16.5	12	15	16.5	17.5	19	17	18.5	19.5	21
TAL040 E	17.5	17.5	17.5	12.5	19.5	19.5	19.5	14	17.5	19	20	22	19.5	21	22	24.5
TAL040 F	20	20	20	14	22	22	22	15.5	20	22	23	25	22	24.5	26	27.5
TAL042 A	25	25	25	15	27.5	27.5	27.5	16.5	29	31.5	31.5	31.5	32	34	35	35
TAL042 B	27	27	27	16	30	30	30	18	30	32	34	34	32.5	35	37.5	37.5
TAL042 C	31	32	32	19	34	35	35	21	33.5	37	39	40	37	40.5	43	44
TAL042 D	35	35	35	22	38.5	38.5	38.5	24	37.5	40.5	43	44	41.5	44.5	47	48
TAL042 E	39.5	40	40	25	43.5	45	45	28	41.5	45.5	48.5	50	46	50	53	55
TAL042 F	43	45	45	27	47.5	50	50	30	44	48	51	56.5	48.5	52.5	56	62.5
TAL042 G	47.5	50	50	30	52.5	55	55	33	49	54	56.5	62.5	54	59	62	69
TAL042 H	58	60	60	36	64	66	66	40	57	63	67	75	63	69	73.5	82.5
TAL044 A	70	70	70	40	77	77	77	44	69	76	80	88	76	83	88	96
TAL044 B	80	80	80	40	88	88	88	44	79	87	92	100	87	95	101	110
TAL044 C	90	90	90	48	100	100	100	53	89	98	103	113	98	107	113	124
TAL044 D	100	100	100	48	110	110	110	53	99	108	115	125	109	119	126	138
TAL044 E	125	125	125	67	138	138	138	74	124	135	143	156	136	149	158	172
TAL044 H	135	135	135	67	149	149	149	74	134	146	155	169	147	161	170	186
TAL044 J	150	150	150	73	165	165	165	80	148	163	172	188	163	179	189	206
TAL044 K	165	165	165	80	181	181	181	88	163	179	189	206	178	195	206	225



Low Voltage Alternators - 4 pole

TAL040 - TAL042 - TAL044 Three phase 10 to 165 kVA - 50 Hz / 12.5 to 206 kVA - 60 Hz

Efficiencies TAL040 : 400 V - 50 Hz (— P.F.: 0.8) (----- P.F.: 1)

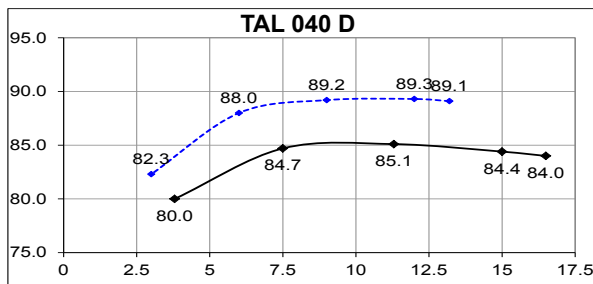
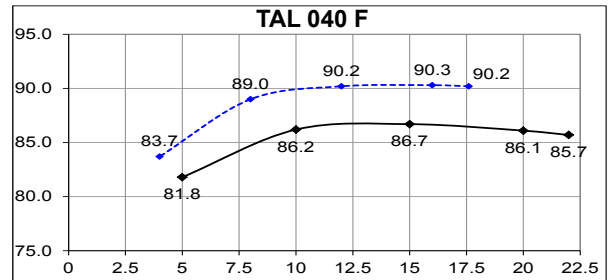
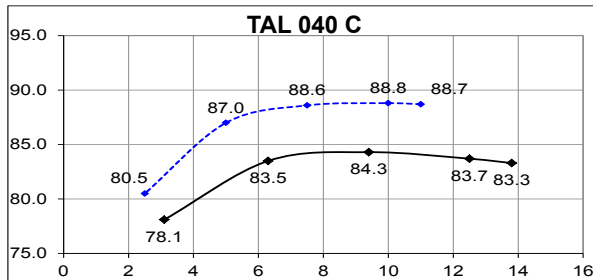
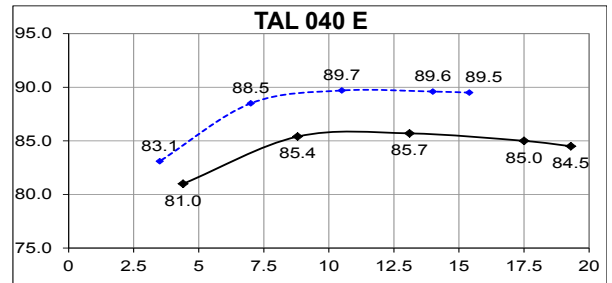
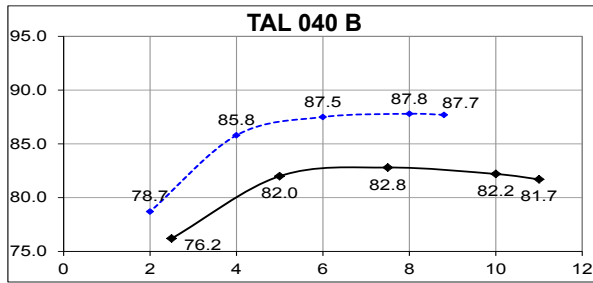

Reactances (%). Time constants (ms) - Class H / 400 V

	B	C	D	E	F
Kcc Short-circuit ratio	0.7	0.56	0.6	0.6	0.61
Xd Direct-axis synchro. reactance unsaturated	167	209	191	195	194
Xq Quadrature-axis synchro. reactance unsaturated	100	125	114	117	116
T'do No-load transient time constant	719	719	837	878	926
X'd Direct-axis transient reactance saturated	17.2	21.5	16.9	16.4	15.5
T'd Short-circuit transient time constant	74	74	74	74	74
X''d Direct-axis subtransient reactance saturated	8.6	10.7	8.4	8.2	7.7
T''d Subtransient time constant	7	7	7.4	7	7
X''q Quadrature-axis subtransient reactance saturated	16.1	20.1	16.9	16.9	16.3
Xo Zero sequence reactance	0.71	0.89	0.7	0.68	0.64
X2 Negative sequence reactance saturated	12.36	15.45	12.69	12.58	12.03
Ta Armature time constant	11	11	11	11	11

Other class H / 400 V data

	B	C	D	E	F
io (A) No-load excitation current	0.77	0.77	0.76	0.75	0.72
ic (A) On-load excitation current	1.93	2.28	2.04	2.04	1.94
uc (V) On-load excitation voltage	23.5	27.7	24.7	24.8	23.4
ms Response time ($\Delta U = 20\%$ transient)	500	500	500	500	500
kVA Start ($\Delta U = 20\%$ cont. or $\Delta U = 30\%$ trans.)	14.7	14.7	23.3	28.2	34.8
% Transient ΔU (on-load 4/4) SHUNT - P.F.: 0.8 LAG	21	23.8	19.8	19	18
W No-load losses	461	461	540	590	645
W Heat dissipation	1588	2149	2055	2245	2342

Low Voltage Alternators - 4 pole

TAL040 - TAL042 - TAL044 Three phase 10 to 165 kVA - 50 Hz / 12.5 to 206 kVA - 60 Hz

Transient voltage variation TAL040 : 400V - 50 Hz

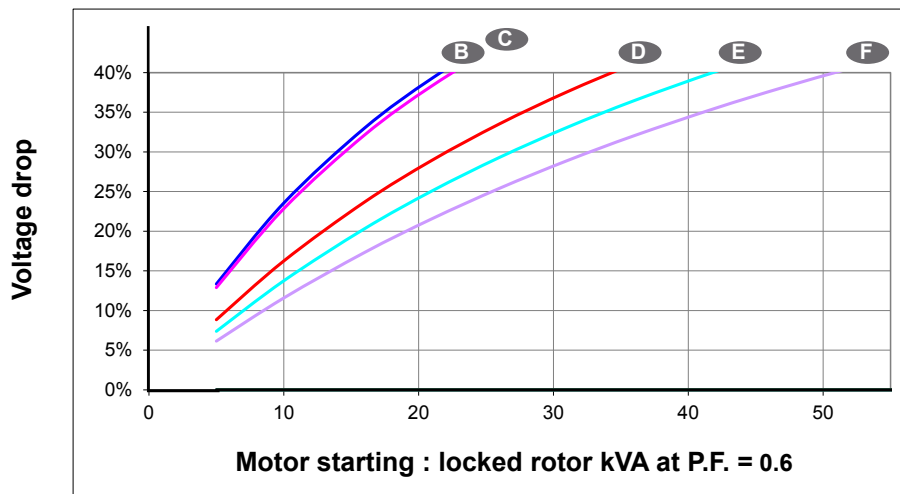
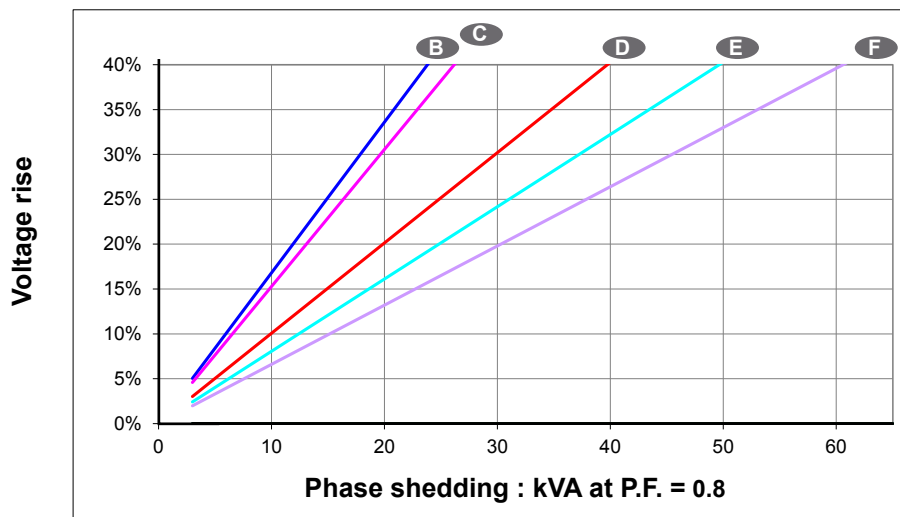
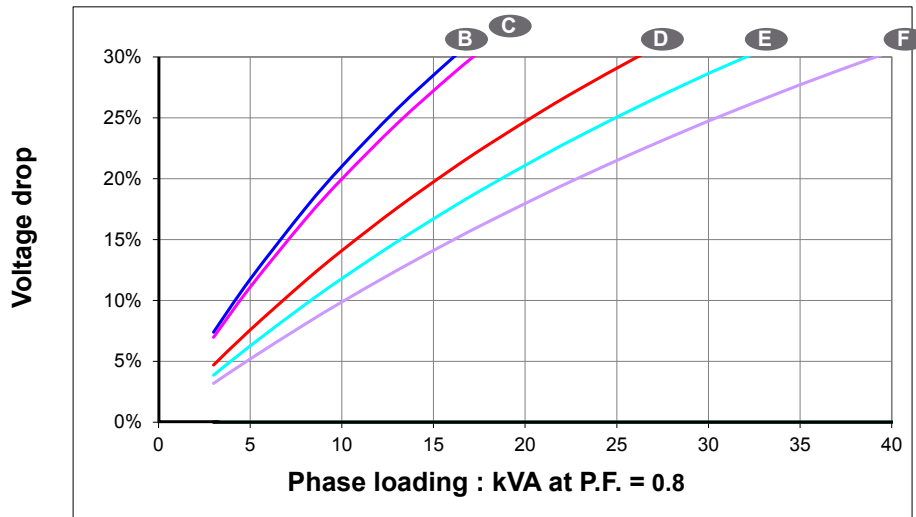

Low Voltage Alternators - 4 pole

TAL040 - TAL042 - TAL044 Three phase 10 to 165 kVA - 50 Hz / 12.5 to 206 kVA - 60 Hz

Efficiencies TAL040 : 480 V - 60 Hz (— P.F.: 0.8) (----- P.F.: 1)

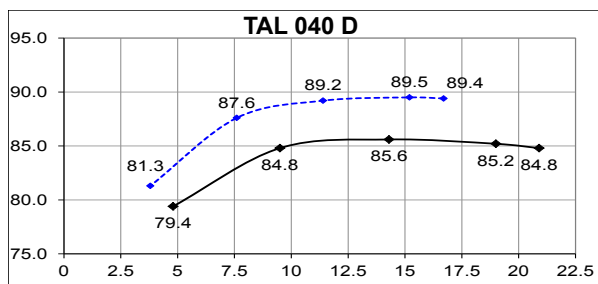
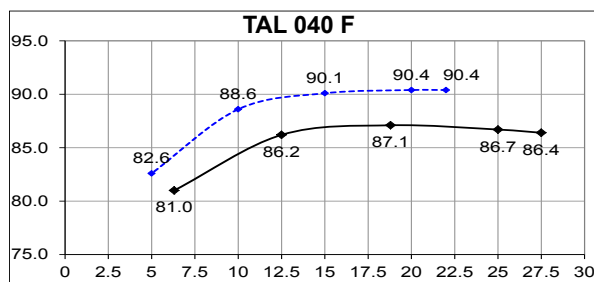
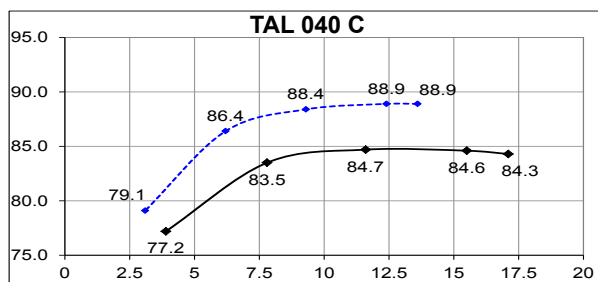
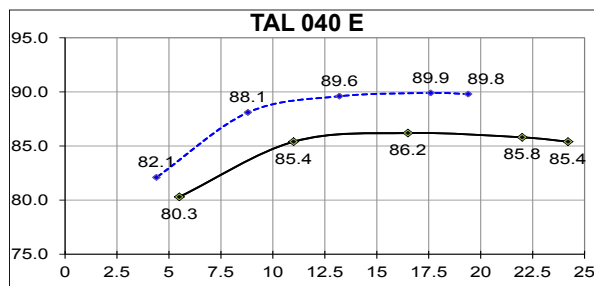
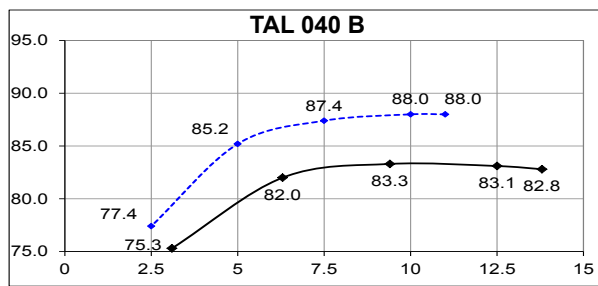

Reactances (%). Time constants (ms) - Class H / 480 V

	B	C	D	E	F
Kcc Short-circuit ratio	0.67	0.54	0.57	0.57	0.58
Xd Direct-axis synchro. reactance unsaturated	174	216	201	205	202
Xq Quadrature-axis synchro. reactance unsaturated	104	129	121	123	121
T'do No-load transient time constant	719	719	837	878	926
X'd Direct-axis transient reactance saturated	17.9	22.2	17.8	17.2	16.1
T'd Short-circuit transient time constant	74	74	74	74	74
X''d Direct-axis subtransient reactance saturated	8.9	11.1	8.9	8.6	8
T''d Subtransient time constant	7	7	7.4	7	7
X''q Quadrature-axis subtransient reactance saturated	16.7	20.7	17.8	17.7	17
Xo Zero sequence reactance	0.74	0.92	0.74	0.72	0.67
X2 Negative sequence reactance saturated	12.87	15.96	13.39	13.18	12.54
Ta Armature time constant	11	11	11	11	11

Other class H / 480 V data

	B	C	D	E	F
io (A) No-load excitation current	0.77	0.77	0.76	0.75	0.72
ic (A) On-load excitation current	1.96	2.3	2.09	2.08	1.96
uc (V) On-load excitation voltage	23.9	28	25.4	25.3	23.8
ms Response time ($\Delta U = 20\%$ transient)	500	500	500	500	500
kVA Start ($\Delta U = 20\%$ cont. or $\Delta U = 30\%$ trans.)	17.7	17.7	28	34.1	41.7
% Transient ΔU (on-load 4/4) SHUNT - P.F.: 0.8 LAG	21.5	24.3	20.4	19.5	18.5
W No-load losses	643	643	755	825	904
W Heat dissipation	1855	2440	2438	2643	2752

Low Voltage Alternators - 4 pole

TAL040 - TAL042 - TAL044 Three phase 10 to 165 kVA - 50 Hz / 12.5 to 206 kVA - 60 Hz

Transient voltage variation TAL040 : 480V - 60 Hz

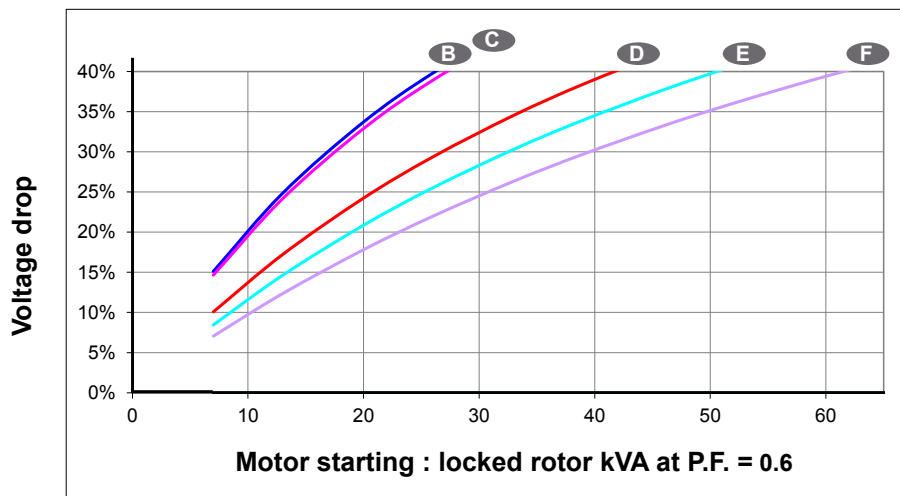
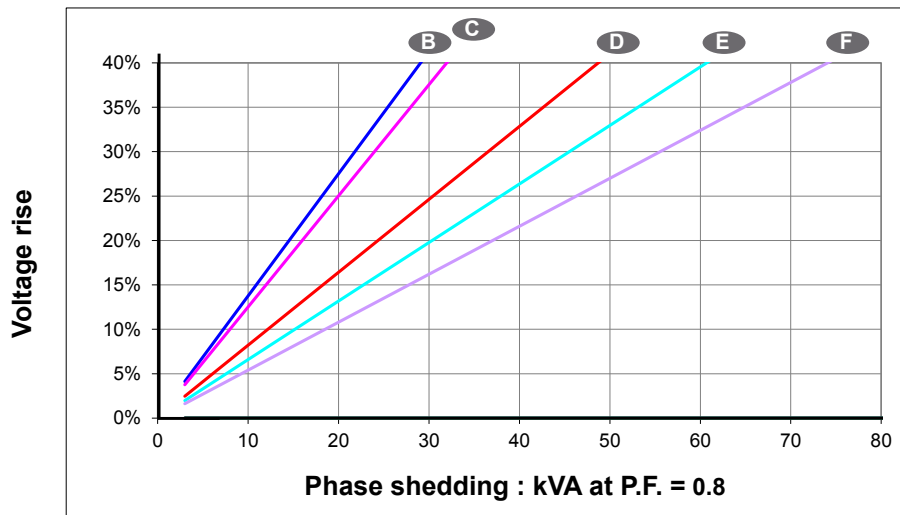
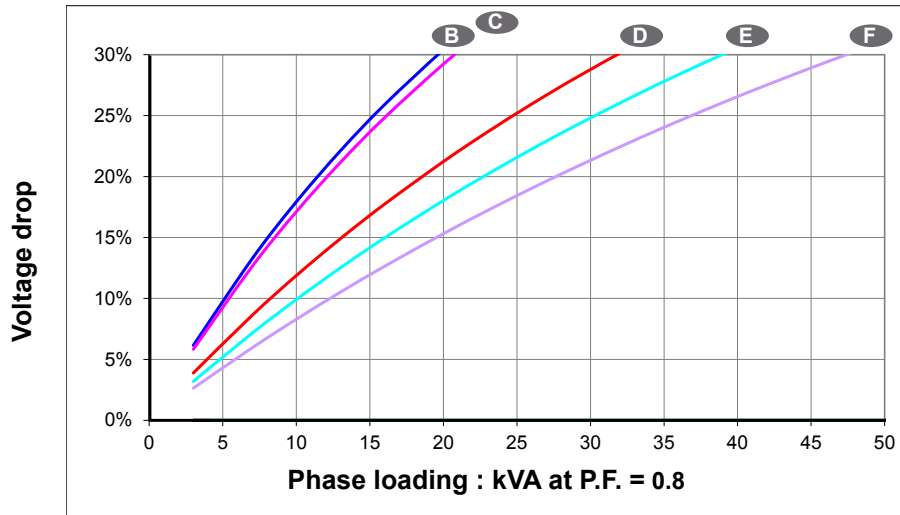

Low Voltage Alternators - 4 pole

TAL040 - TAL042 - TAL044 Three phase 10 to 165 kVA - 50 Hz / 12.5 to 206 kVA - 60 Hz

3-phase short-circuit curves at no load and rated speed TAL040 (star connection Y)

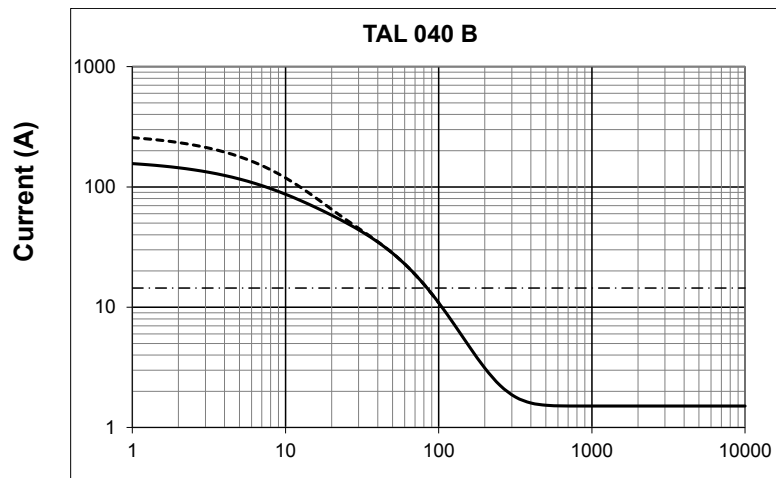

Symmetrical
Asymmetrical

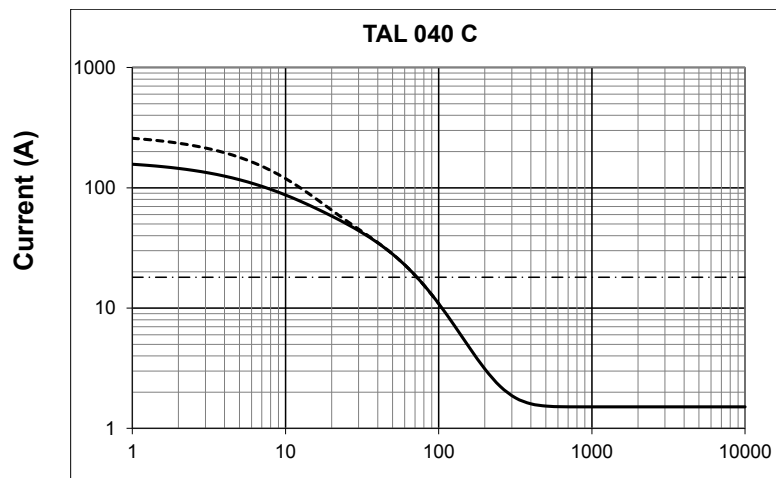

Symmetrical
Asymmetrical

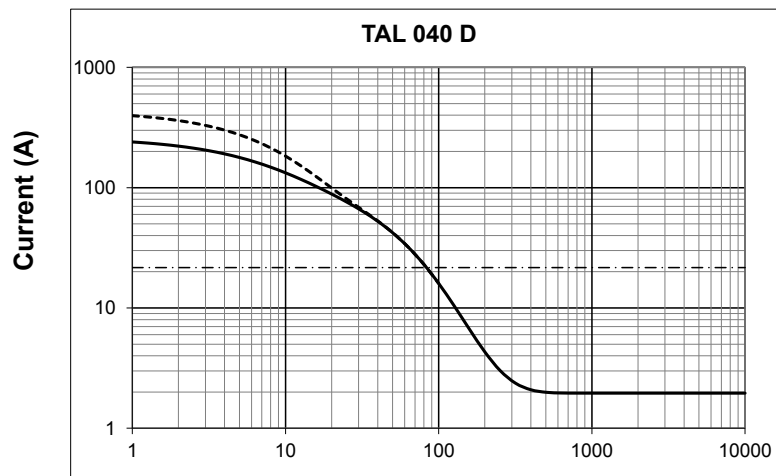

Symmetrical
Asymmetrical

Influence due to connection

For (Δ) connection, use the following multiplication factor:
- Current value x 1.732.

Low Voltage Alternators - 4 pole

TAL040 - TAL042 - TAL044 Three phase 10 to 165 kVA - 50 Hz / 12.5 to 206 kVA - 60 Hz

3-phase short-circuit curves at no load and rated speed TAL040 (star connection Y)

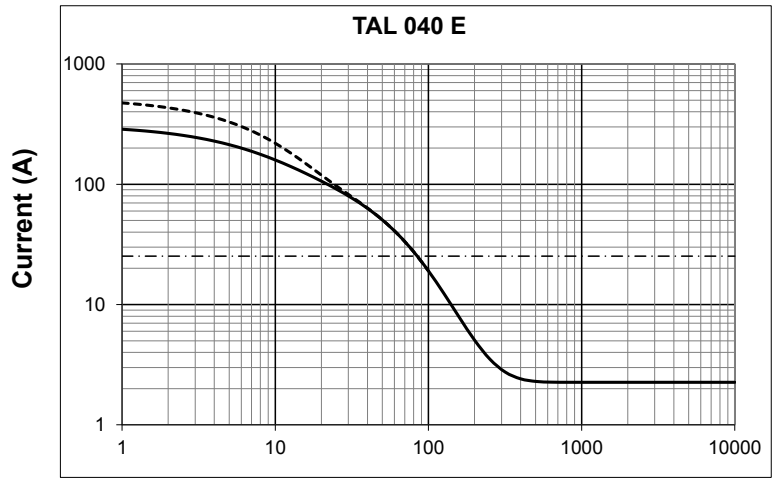

Symmetrical
Asymmetrical

Time (ms)

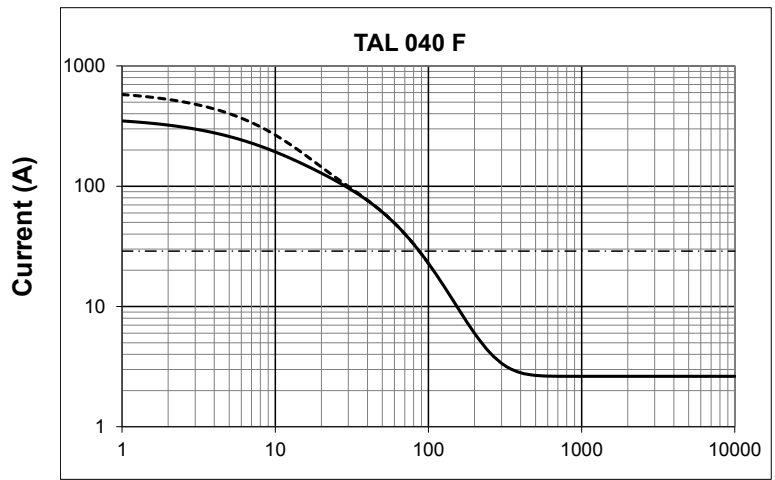

Symmetrical
Asymmetrical

Time (ms)

Influence due to short-circuit

Curves are based on a three-phase short-circuit. For other types of short-circuit, use the following multiplication factors.

	3 - phase	2 - phase L / L	1 - phase L / N
Instantaneous (max.)	1	0.87	1.3
Continuous	1	1.5	2.2
Maximum duration (AREP/PMG)		1.5	

Low Voltage Alternators - 4 pole

TAL040 - TAL042 - TAL044 Three phase 10 to 165 kVA - 50 Hz / 12.5 to 206 kVA - 60 Hz

Efficiencies TAL042 : 400 V - 50 Hz (— P.F.: 0.8) (----- P.F.: 1)

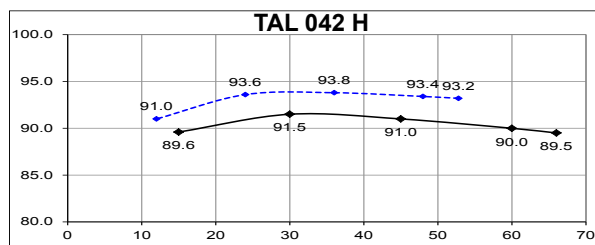
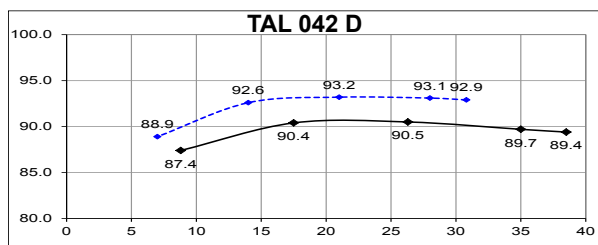
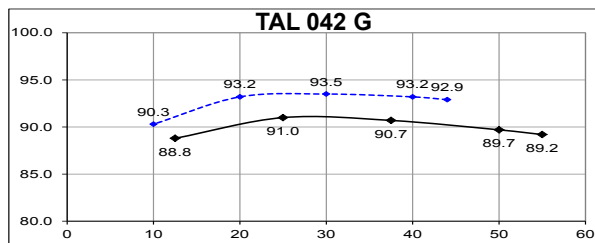
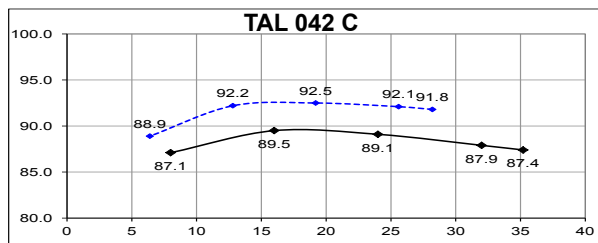
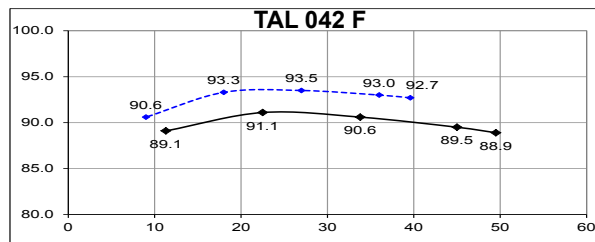
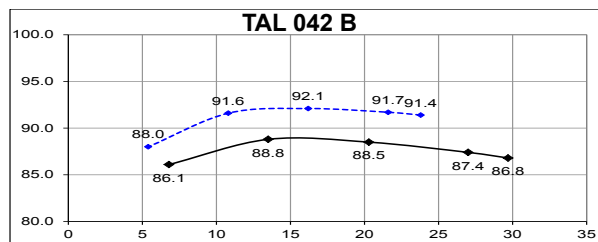
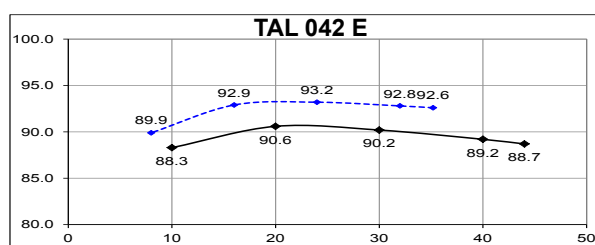
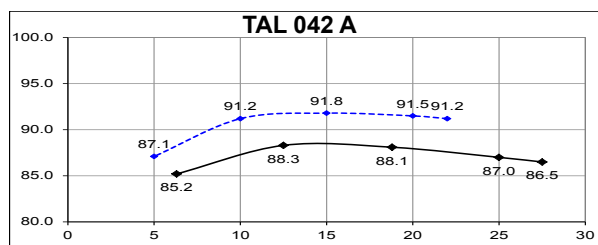

Reactances (%). Time constants (ms) - Class H / 400 V

		A	B	C	D	E	F	G	H
Kcc	Short-circuit ratio	0.49	0.46	0.44	0.49	0.42	0.40	0.43	0.40
Xd	Direct-axis synchro. reactance unsaturated	257	267	279	246	281	294	283	303
Xq	Quadrature-axis synchro. reactance unsaturated	154	160	167	147	168	176	170	182
T'do	No-load transient time constant	786	813	861	944	944	980	998	1031
X'd	Direct-axis transient reactance saturated	16.3	16.4	16.2	13.0	14.8	15.0	14.1	14.7
T'd	Short-circuit transient time constant	50	50	50	50	50	50	50	50
X''d	Direct-axis subtransient reactance saturated	8.1	8.2	8.1	6.5	7.4	7.5	7.0	7.3
T''d	Subtransient time constant	5	5	5	5	5	5	5	5
X''q	Quadrature-axis subtransient reactance saturated	11.5	11.6	11.5	9.2	10.6	10.7	10.1	10.5
Xo	Zero sequence reactance	0.86	0.68	0.67	0.54	0.62	0.62	0.59	0.61
X2	Negative sequence reactance saturated	9.88	9.91	9.82	7.89	9.02	9.12	8.61	8.93
Ta	Armature time constant	8.0	8.0	8.0	8.0	8.0	8.0	8.0	8.0

Other class H / 400 V data

		A	B	C	D	E	F	G	H
io (A)	No-load excitation current	0.53	0.50	0.49	0.47	0.47	0.45	0.48	0.48
ic (A)	On-load excitation current	1.73	1.72	1.78	1.55	1.76	1.78	1.88	2.07
uc (V)	On-load excitation voltage	29.5	29.3	30.1	26.3	29.4	29.6	30.9	33.2
ms	Response time ($\Delta U = 20\%$ transient)	500	500	500	500	500	500	500	500
kVA	Start ($\Delta U = 20\%$ cont. or $\Delta U = 30\%$ trans.)	35.2	37.6	45.4	61.7	62.0	68.6	81.3	94.0
%	Transient ΔU (on-load 4/4) SHUNT - P.F.: 0.8 _{LAG}	20.9	20.9	20.8	18.2	19.7	19.8	19.1	19.5
W	No-load losses	731	726	778	882	882	903	1057	1152
W	Heat dissipation	2967	3112	3491	3183	3865	4217	4588	5330

Low Voltage Alternators - 4 pole

TAL040 - TAL042 - TAL044 Three phase 10 to 165 kVA - 50 Hz / 12.5 to 206 kVA - 60 Hz

Transient voltage variation TAL042 : 400V - 50 Hz

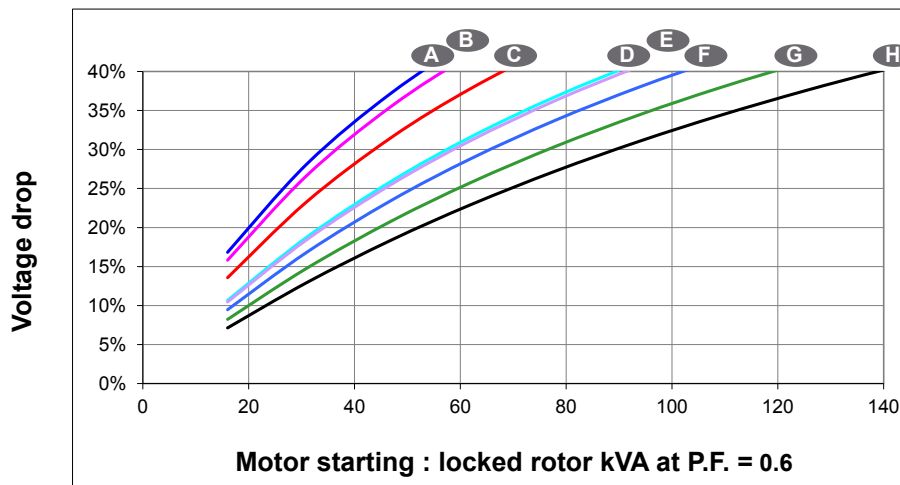
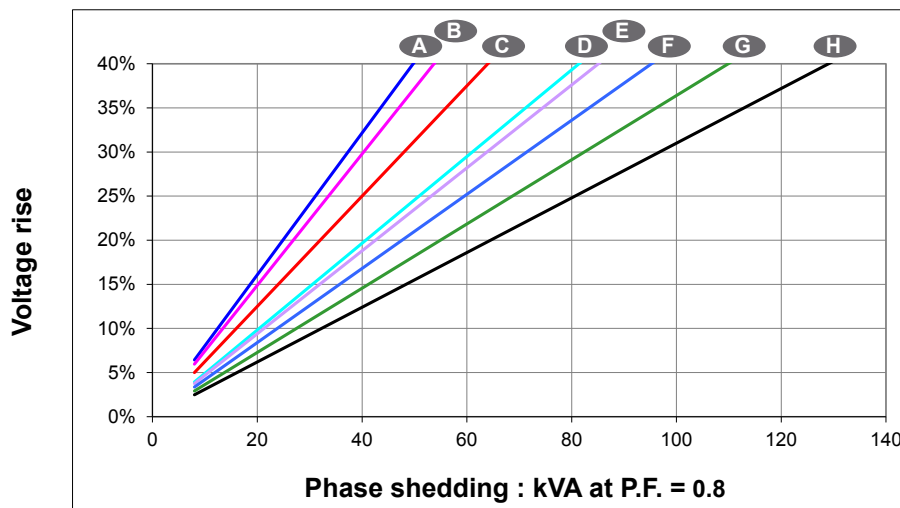
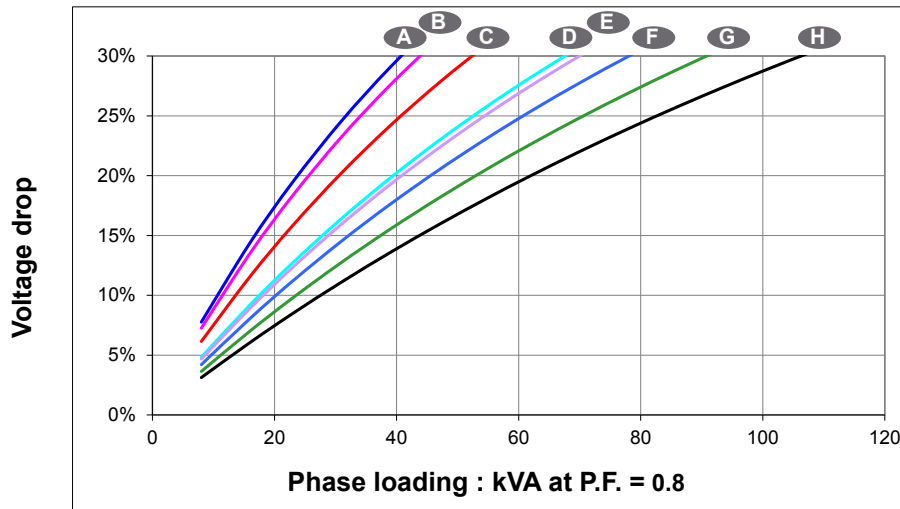

Low Voltage Alternators - 4 pole

TAL040 - TAL042 - TAL044 Three phase 10 to 165 kVA - 50 Hz / 12.5 to 206 kVA - 60 Hz

Efficiencies TAL042 : 480 V - 60 Hz (— P.F.: 0.8) (----- P.F.: 1)

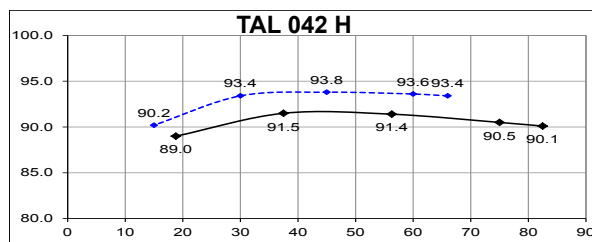
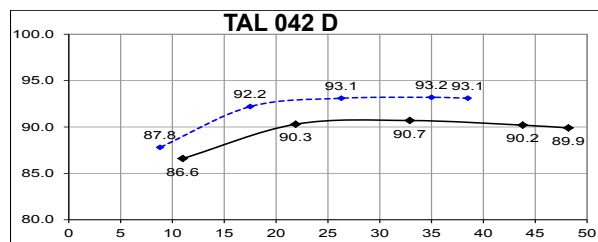
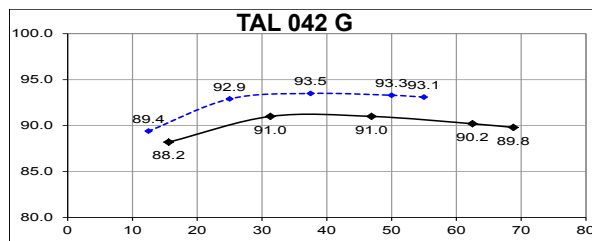
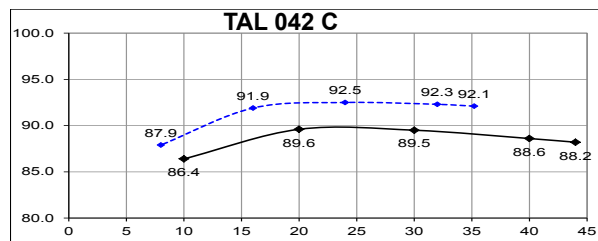
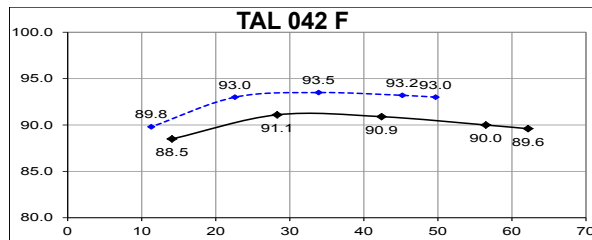
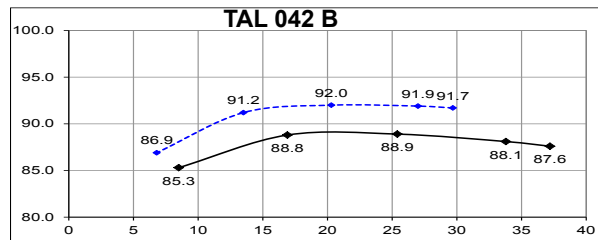
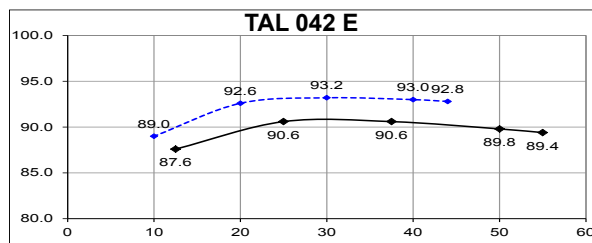
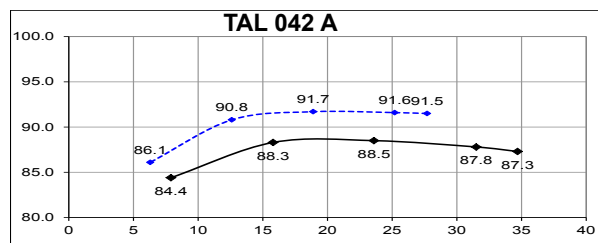

Reactances (%). Time constants (ms) - Class H / 480 V

	A	B	C	D	E	F	G	H
Kcc Short-circuit ratio	0.47	0.44	0.42	0.47	0.41	0.38	0.41	0.38
Xd Direct-axis synchro. reactance unsaturated	270	279	292	256	292	308	295	316
Xq Quadrature-axis synchro. reactance unsaturated	162	167	175	153	175	185	177	189
T'do No-load transient time constant	786	813	861	944	944	980	998	1031
X'd Direct-axis transient reactance saturated	17.2	17.1	16.9	13.5	15.5	15.7	14.7	15.3
T'd Short-circuit transient time constant	50	50	50	50	50	50	50	50
X''d Direct-axis subtransient reactance saturated	8.6	8.5	8.4	6.7	7.7	7.8	7.3	7.6
T''d Subtransient time constant	5	5	5	5	5	5	5	5
X''q Quadrature-axis subtransient reactance saturated	12.1	12.1	12.0	9.6	11.0	11.2	10.5	10.5
Xo Zero sequence reactance	0.71	0.71	0.7	0.55	0.64	0.65	0.61	0.63
X2 Negative sequence reactance saturated	10.37	10.35	10.24	8.22	9.39	9.55	8.97	9.30
Ta Armature time constant	8.0	8.0	8.0	8.0	8.0	8.0	8.0	8.0

Other class H / 480 V data

io (A) No-load excitation current	0.53	0.50	0.49	0.47	0.47	0.45	0.48	0.48
ic (A) On-load excitation current	1.75	1.74	1.79	1.56	1.76	1.78	1.86	2.02
uc (V) On-load excitation voltage	30.2	29.8	30.6	26.7	29.8	30.1	31.2	33.3
ms Response time ($\Delta U = 20\%$ transient)	500	500	500	500	500	500	500	500
kVA Start ($\Delta U = 20\%$ cont. or $\Delta U = 30\%$ trans.)	42.0	45.2	54.4	74.0	74.3	82.3	97.5	112.7
% Transient ΔU (on-load 4/4) SHUNT - P.F.: 0.8 _{LAG}	21.5	21.5	21.3	18.6	20.2	20.4	19.6	20.0
W No-load losses	1043	1040	1114	1264	1264	1295	1507	1642
W Heat dissipation	3500	3640	4082	3771	4529	4970	5383	6243

Low Voltage Alternators - 4 pole

TAL040 - TAL042 - TAL044 Three phase 10 to 165 kVA - 50 Hz / 12.5 to 206 kVA - 60 Hz

Transient voltage variation TAL042 : 480V - 60 Hz

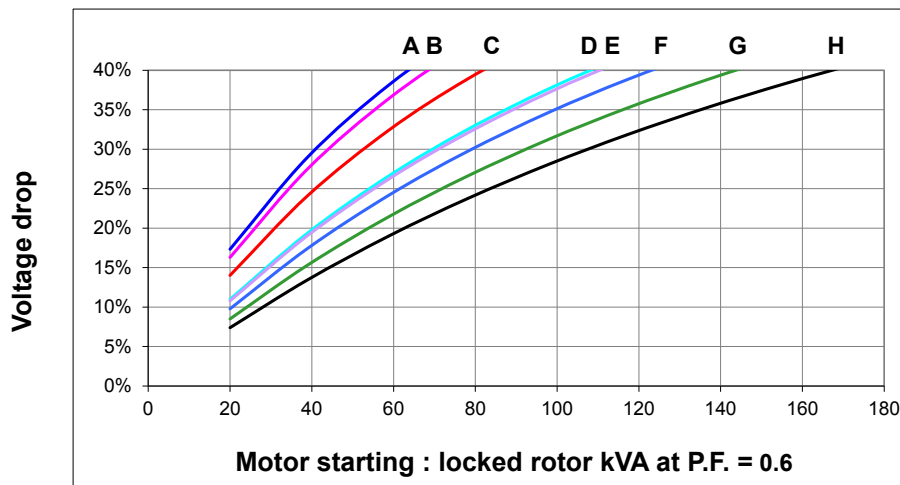
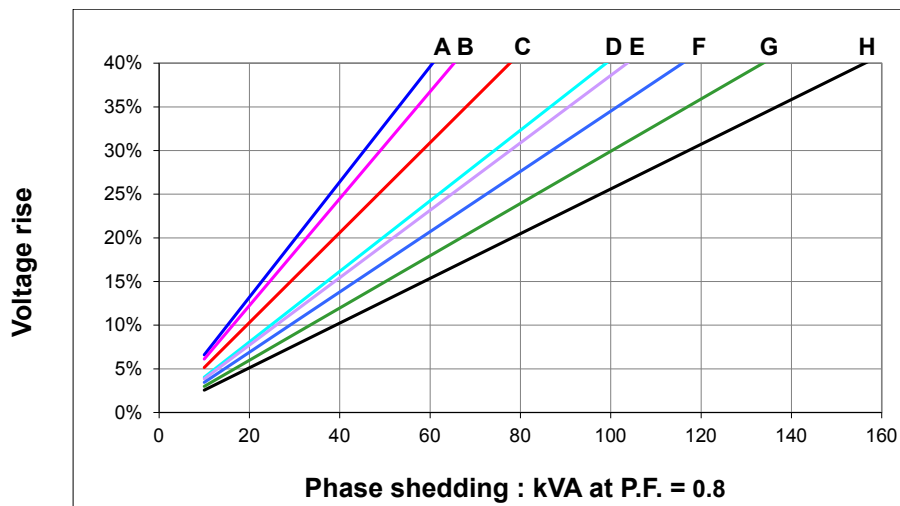
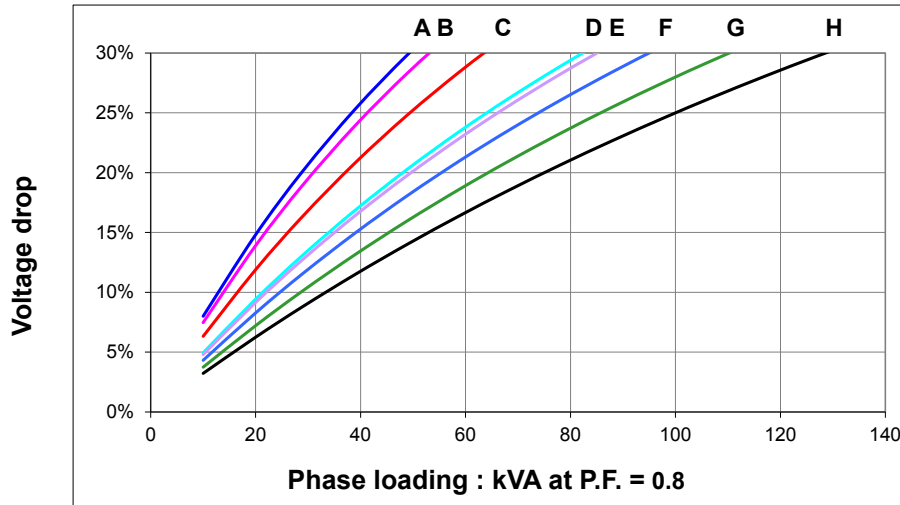

Low Voltage Alternators - 4 pole

TAL040 - TAL042 - TAL044 Three phase 10 to 165 kVA - 50 Hz / 12.5 to 206 kVA - 60 Hz

3-phase short-circuit curves at no load and rated speed TAL042 (star connection Y)

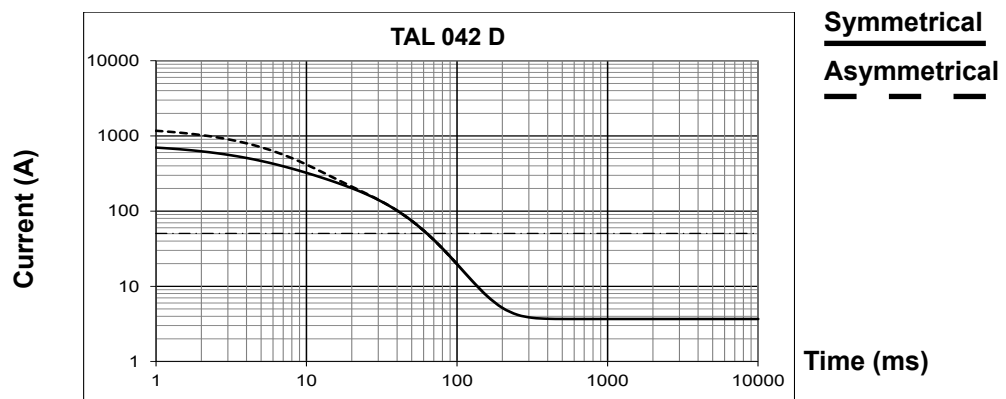
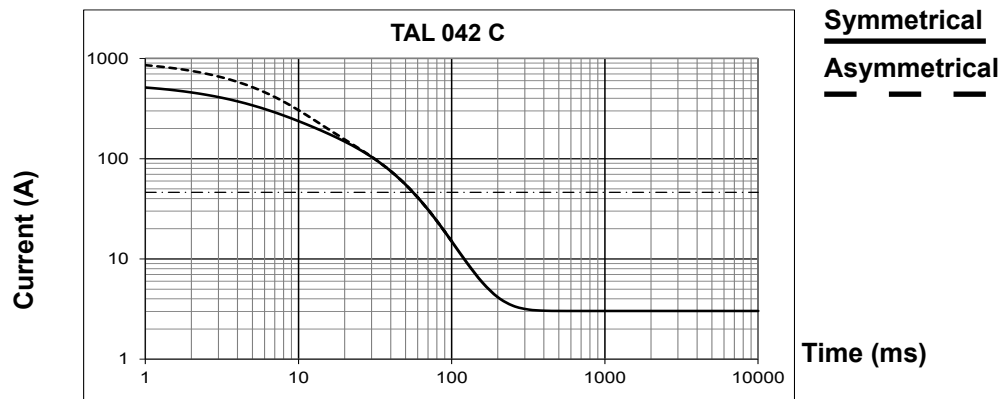
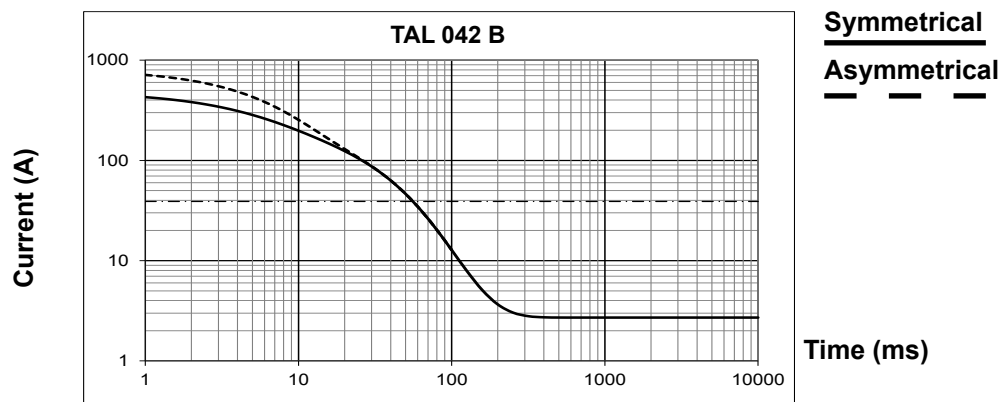
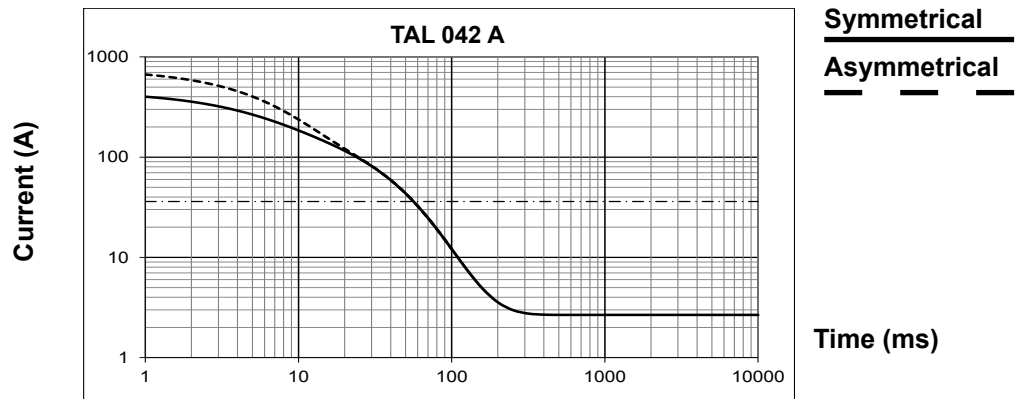

Influence due to connection

For (Δ) connection, use the following multiplication factor:

- Current value x 1.732.

Low Voltage Alternators - 4 pole

TAL040 - TAL042 - TAL044 Three phase 10 to 165 kVA - 50 Hz / 12.5 to 206 kVA - 60 Hz

3-phase short-circuit curves at no load and rated speed TAL042 (star connection Y)

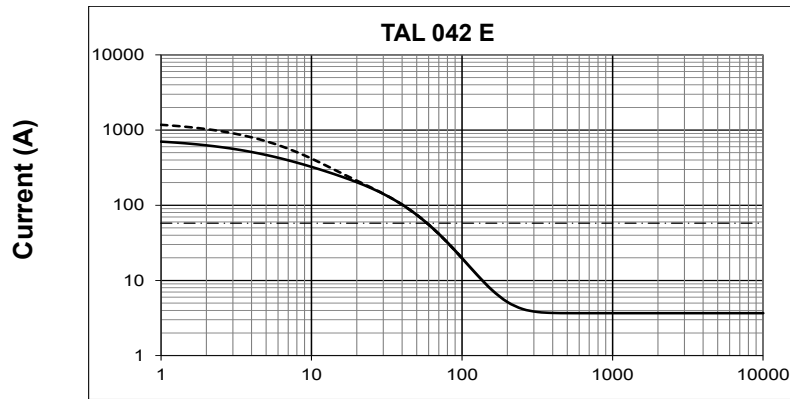

Symmetrical
Asymmetrical

Time (ms)

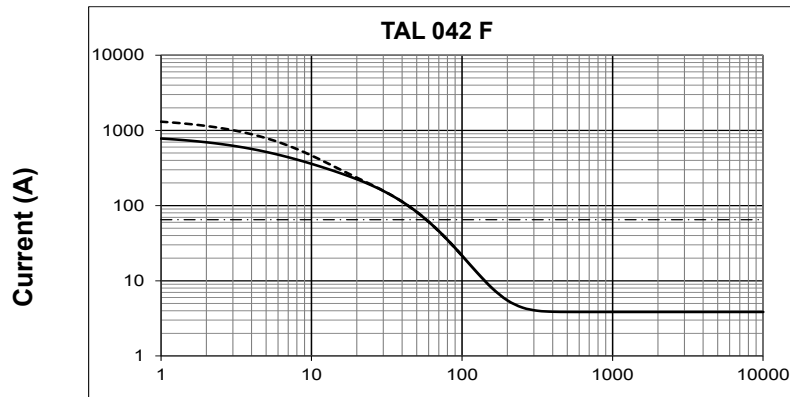

Symmetrical
Asymmetrical

Time (ms)

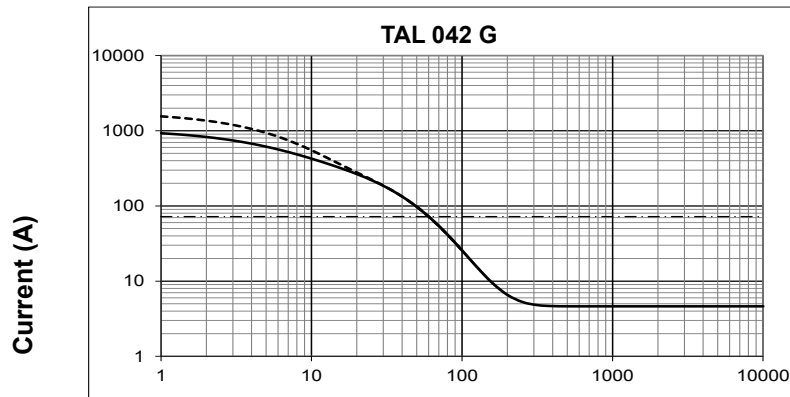

Symmetrical
Asymmetrical

Time (ms)

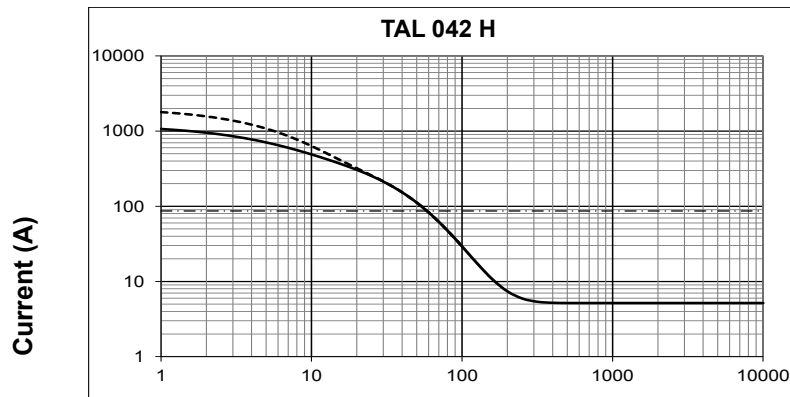

Symmetrical
Asymmetrical

Time (ms)

Influence due to short-circuit

Curves are based on a three-phase short-circuit.
For other types of short-circuit,
use the following multiplication factors.

	3 - phase	2 - phase L / L	1 - phase L / N
Instantaneous (max.)	1	0.87	1.3
Continuous	1	1.5	2.2
Maximum duration (AREP/PMG)		1.5	

Low Voltage Alternators - 4 pole

TAL040 - TAL042 - TAL044 Three phase 10 to 165 kVA - 50 Hz / 12.5 to 206 kVA - 60 Hz

Efficiencies TAL044 : 400 V - 50 Hz (— P.F.: 0.8) (----- P.F.: 1)

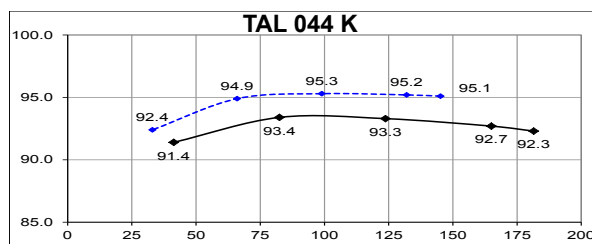
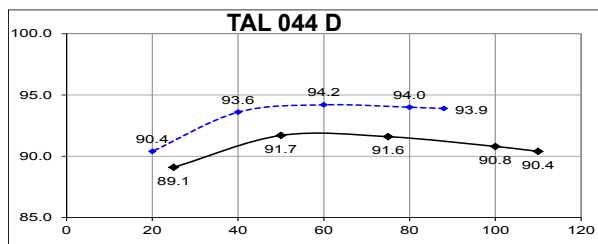
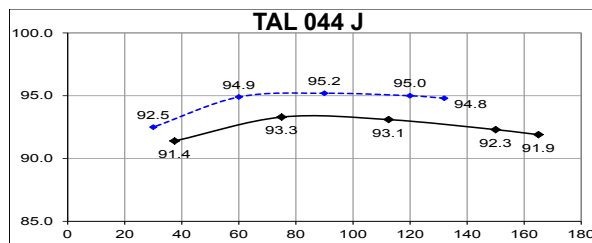
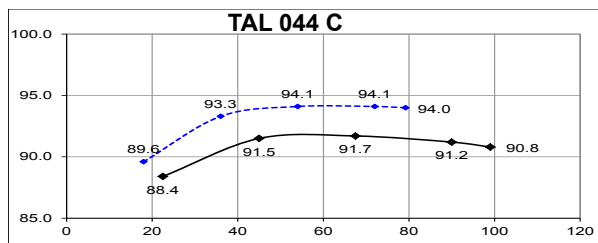
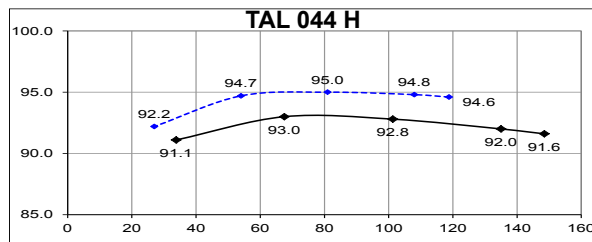
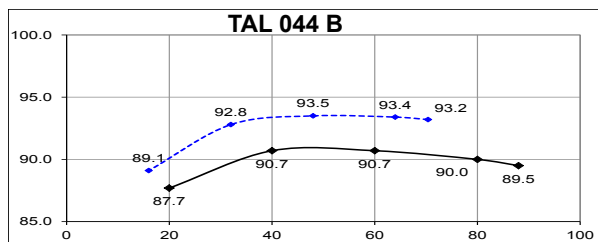
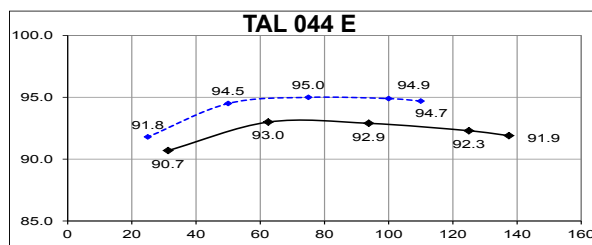
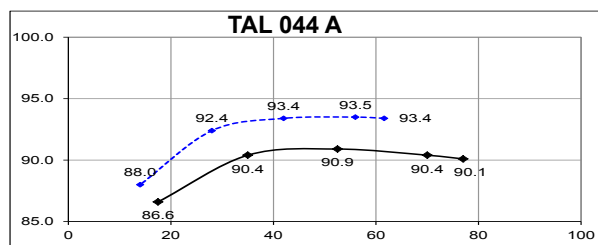

Reactances (%). Time constants (ms) - Class H / 400 V

	A	B	C	D	E	H	J	K
Kcc Short-circuit ratio	0.59	0.52	0.53	0.48	0.43	0.4	0.4	0.42
Xd Direct-axis synchro. reactance unsaturated	291	333	307	341	335	362	359	342
Xq Quadrature-axis synchro. reactance unsaturated	148	170	156	174	171	185	183	174
T'do No-load transient time constant	2475	2475	2308	2308	2154	2154	2112	2077
X'd Direct-axis transient reactance saturated	11.7	13.4	13.3	14.7	15.5	16.8	17	16.4
T'd Short-circuit transient time constant	100	100	100	100	100	100	100	100
X''d Direct-axis subtransient reactance saturated	7	8	7.9	8.8	9.3	10.1	10.2	9.8
T''d Subtransient time constant	10	10	10	10	10	10	10	10
X''q Quadrature-axis subtransient reactance saturated	15.9	18.2	17	18.9	18.9	20.5	20.4	19.5
Xo Zero sequence reactance	0.49	0.56	0.55	0.61	0.64	0.7	0.7	0.68
X2 Negative sequence reactance saturated	11.5	13.14	12.53	13.92	14.17	15.3	15.31	14.72
Ta Armature time constant	15	15	15	15	15	15	15	15

Other class H / 400 V data

io (A) No-load excitation current	0.86	0.86	0.8	0.8	0.67	0.67	0.66	0.68
ic (A) On-load excitation current	2.62	2.98	2.75	3.08	2.57	2.78	2.79	2.83
uc (V) On-load excitation voltage	29.2	32.8	30.1	33.2	31.9	34.3	34.1	34.2
ms Response time ($\Delta U = 20\%$ transient)	500	500	500	500	500	500	500	500
kVA Start ($\Delta U = 20\%$ cont. or $\Delta U = 30\%$ trans.)	125	127	144.5	146.3	211.7	214.3	228	262.4
% Transient ΔU (on-load 4/4) SHUNT - P.F.: 0.8 _{LAG}	16.5	18.1	17.9	19.2	14.3	15	15	14.8
W No-load losses	1980	1980	2142	2142	2281	2281	2449	2763
W Heat dissipation	5900	7094	6923	8055	8315	9335	9910	10391

Low Voltage Alternators - 4 pole

TAL040 - TAL042 - TAL044 Three phase 10 to 165 kVA - 50 Hz / 12.5 to 206 kVA - 60 Hz

Transient voltage variation TAL044 : 400V - 50 Hz

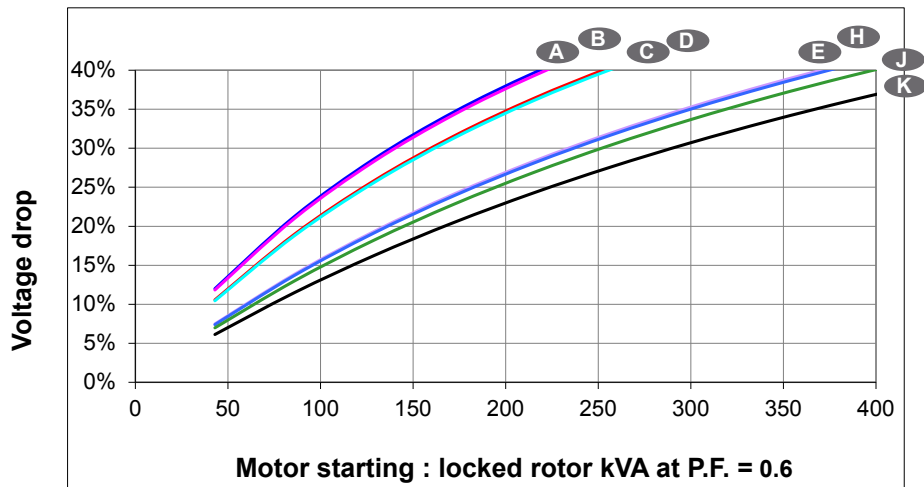
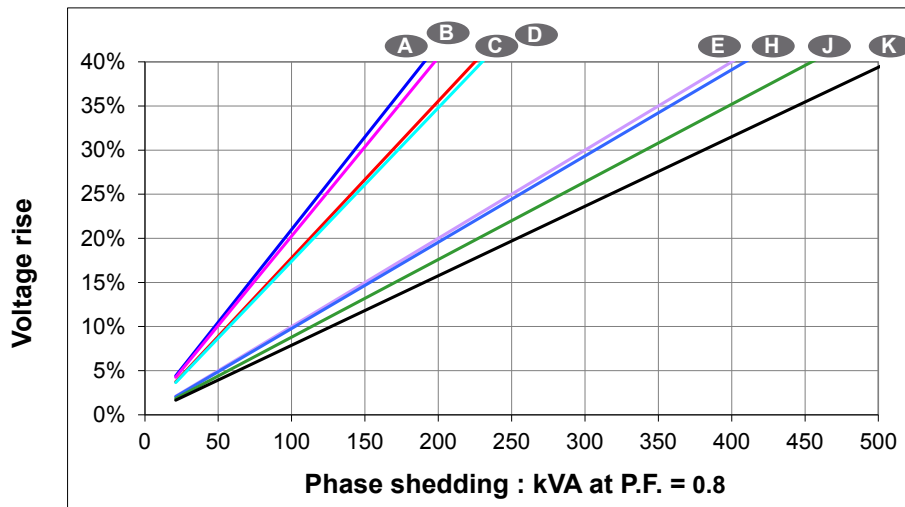
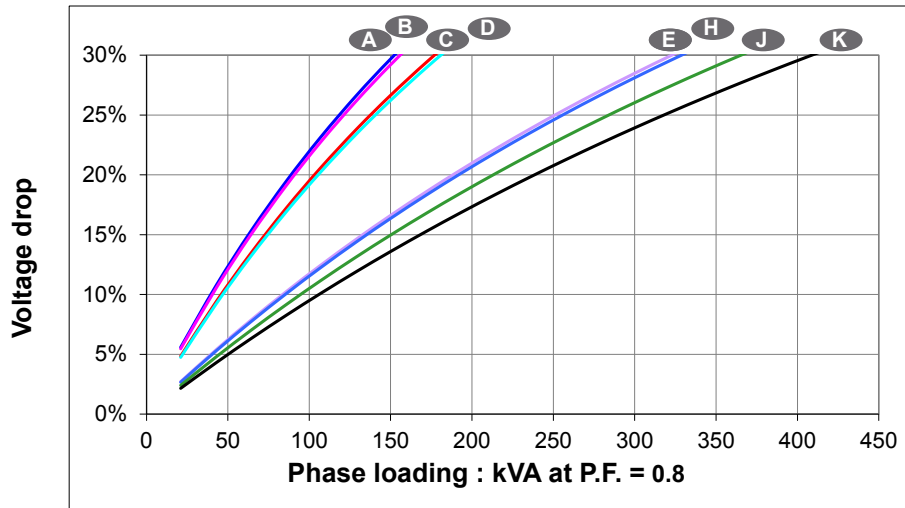

Low Voltage Alternators - 4 pole

TAL040 - TAL042 - TAL044 Three phase 10 to 165 kVA - 50 Hz / 12.5 to 206 kVA - 60 Hz

Efficiencies TAL044 : 480 V - 60 Hz (— P.F.: 0.8) (----- P.F.: 1)

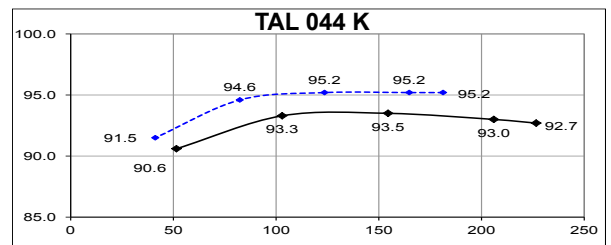
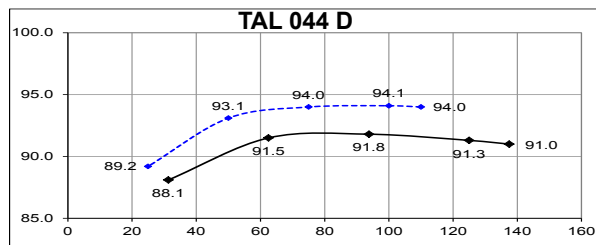
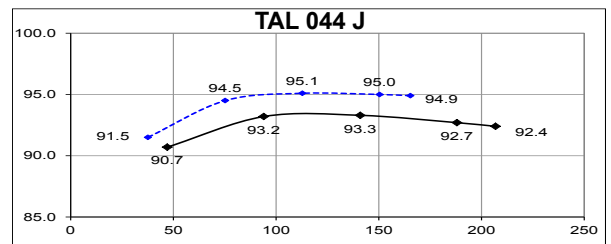
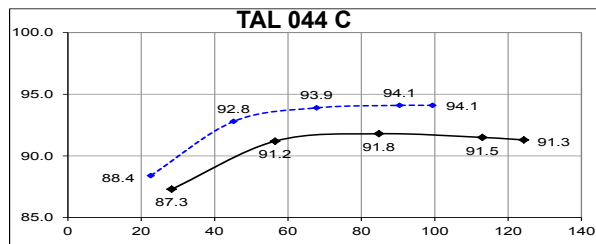
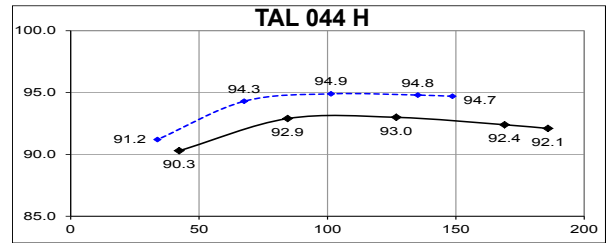
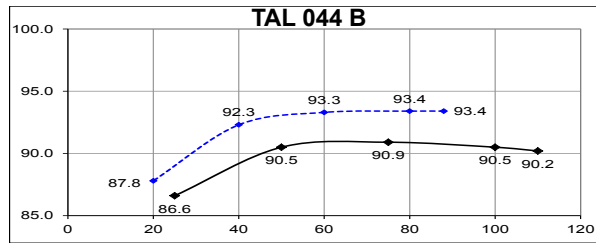
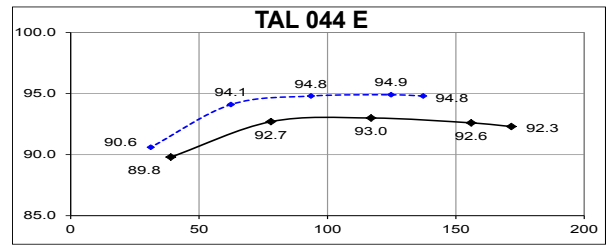
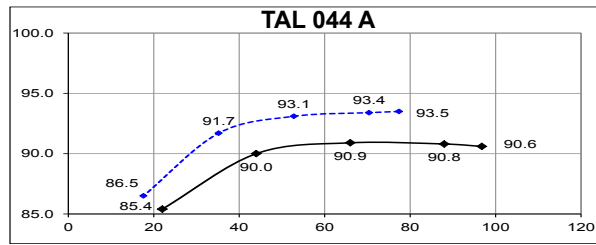

Reactances (%). Time constants (ms) - Class H / 480 V

	A	B	C	D	E	H	J	K
Kcc Short-circuit ratio	0.56	0.49	0.5	0.46	0.41	0.38	0.38	0.4
Xd Direct-axis synchro. reactance unsaturated	305	347	321	355	348	377	375	358
Xq Quadrature-axis synchro. reactance unsaturated	155	177	164	181	177	192	191	182
T'do No-load transient time constant	2475	2475	2308	2308	2154	2154	2112	2077
X'd Direct-axis transient reactance saturated	12.3	14	13.9	15.4	16.1	17.5	17.7	17.2
T'd Short-circuit transient time constant	100	100	100	100	100	100	100	100
X''d Direct-axis subtransient reactance saturated	7.4	8.4	8.3	9.2	9.6	10.5	10.6	10.3
T''d Subtransient time constant	10	10	10	10	10	10	10	10
X''q Quadrature-axis subtransient reactance saturated	16.6	18.9	17.8	19.7	19.6	21.3	21.3	20.4
Xo Zero sequence reactance	0.51	0.58	0.58	0.64	0.67	0.72	0.74	0.71
X2 Negative sequence reactance saturated	12.05	13.69	13.1	14.49	14.69	15.91	15.99	15.39
Ta Armature time constant	15	15	15	15	15	15	15	15

Other class H / 480 V data

io (A) No-load excitation current	0.86	0.86	0.79	0.79	0.67	0.67	0.66	0.67
ic (A) On-load excitation current	2.62	2.94	2.72	3.01	2.58	2.79	2.79	2.79
uc (V) On-load excitation voltage	29.5	32.9	30.3	33.3	32.4	34.9	34.7	34.4
ms Response time ($\Delta U = 20\%$ transient)	500	500	500	500	500	500	500	500
kVA Start ($\Delta U = 20\%$ cont. or $\Delta U = 30\%$ trans.)	150.9	153.1	174.2	175.2	255.2	258.7	275.7	316
% Transient ΔU (on-load 4/4) SHUNT - P.F.: 0.8 _{LAG}	17	18.6	18.5	19.8	14.6	15.4	15.5	15.2
W No-load losses	2918	2918	3156	3156	3388	3388	3610	4018
W Heat dissipation	7112	8359	8300	9486	9884	11051	11746	12263

Low Voltage Alternators - 4 pole

TAL040 - TAL042 - TAL044 Three phase 10 to 165 kVA - 50 Hz / 12.5 to 206 kVA - 60 Hz

Transient voltage variation TAL044 : 480V - 60 Hz

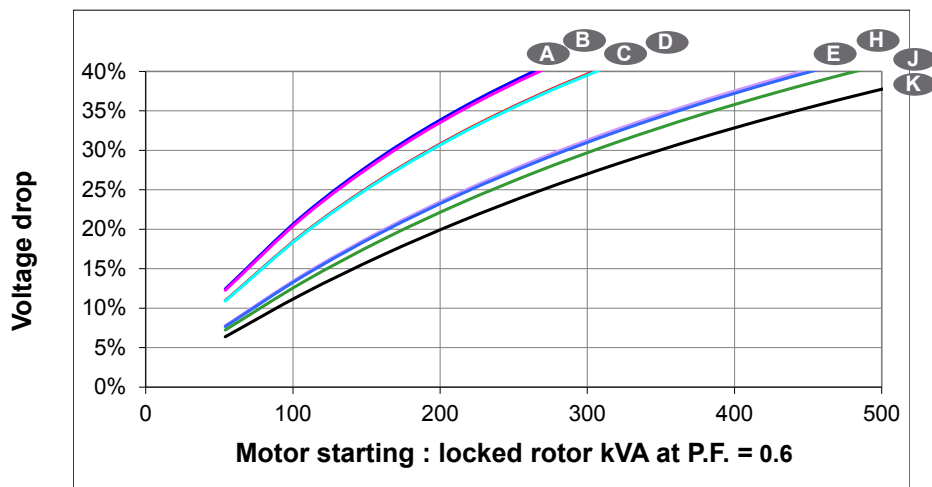
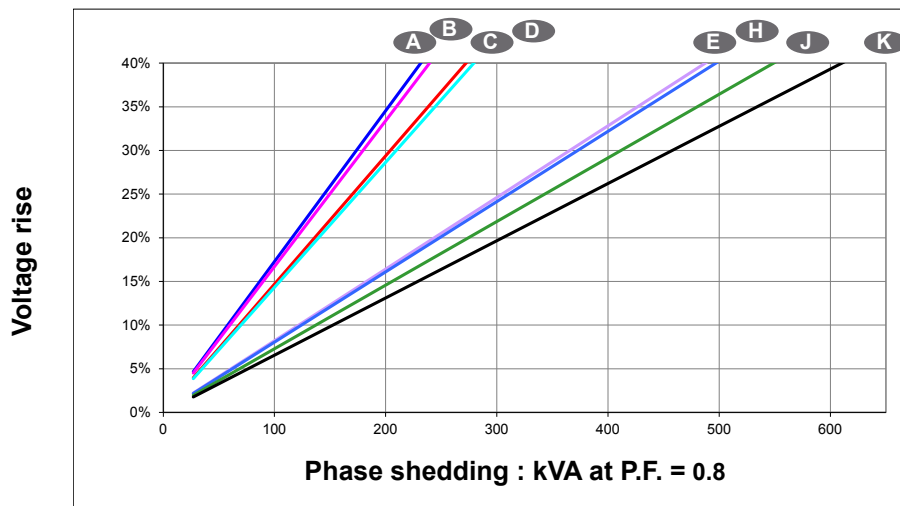
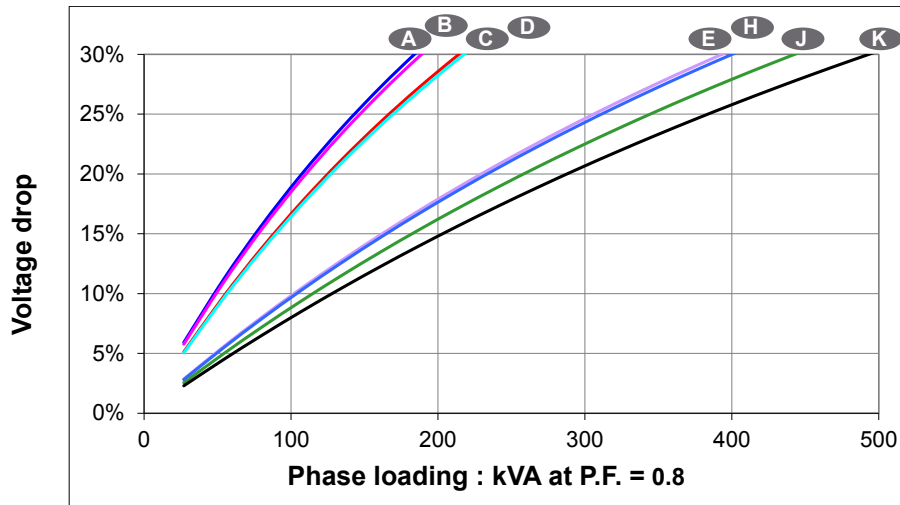

Low Voltage Alternators - 4 pole

TAL040 - TAL042 - TAL044 Three phase 10 to 165 kVA - 50 Hz / 12.5 to 206 kVA - 60 Hz

3-phase short-circuit curves at no load and rated speed TAL044 (star connection Y)

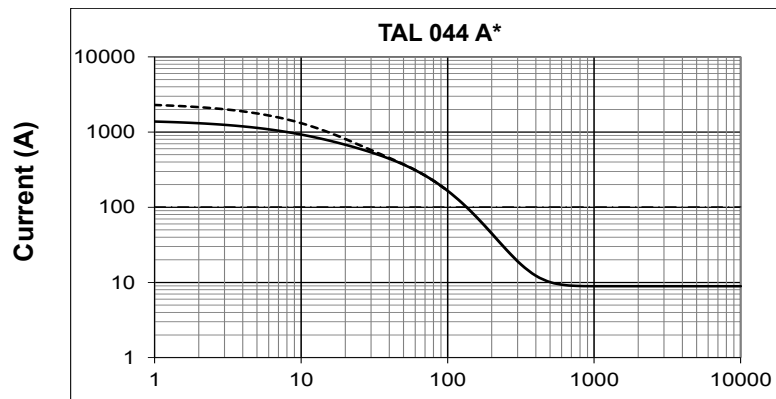

Symmetrical
Asymmetrical

Time (ms)

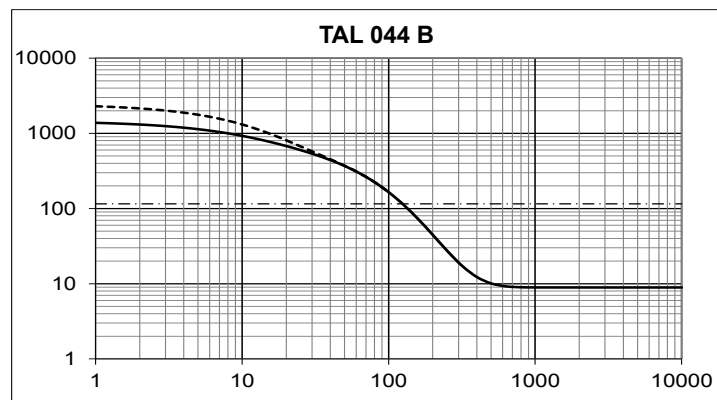

Symmetrical
Asymmetrical

Time (ms)

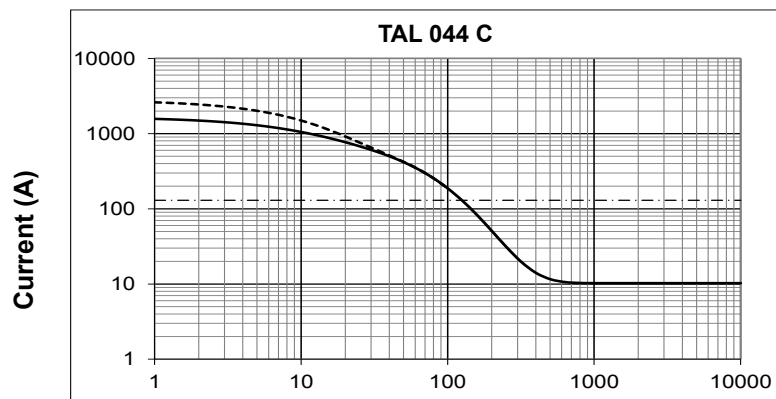

Symmetrical
Asymmetrical

Time (ms)

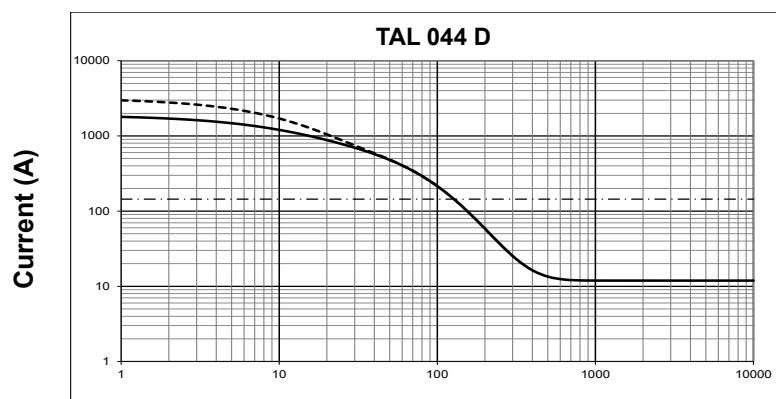

Symmetrical
Asymmetrical

Time (ms)

Influence due to connection

For (Δ) connection, use the following multiplication factor:

- Current value x 1.732.

Low Voltage Alternators - 4 pole

TAL040 - TAL042 - TAL044 Three phase 10 to 165 kVA - 50 Hz / 12.5 to 206 kVA - 60 Hz

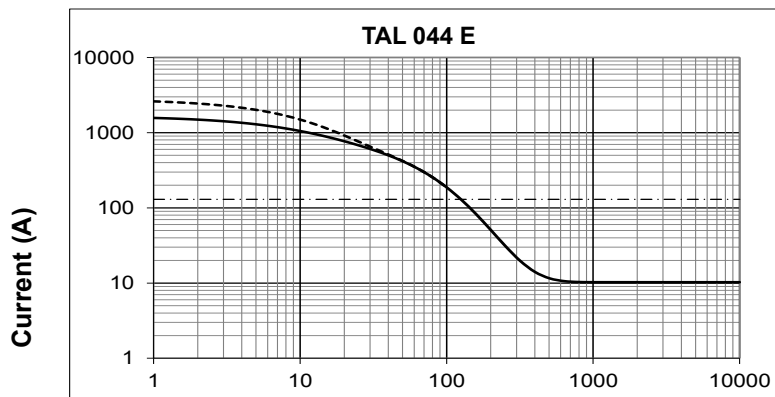

Symmetrical
Asymmetrical

Time (ms)

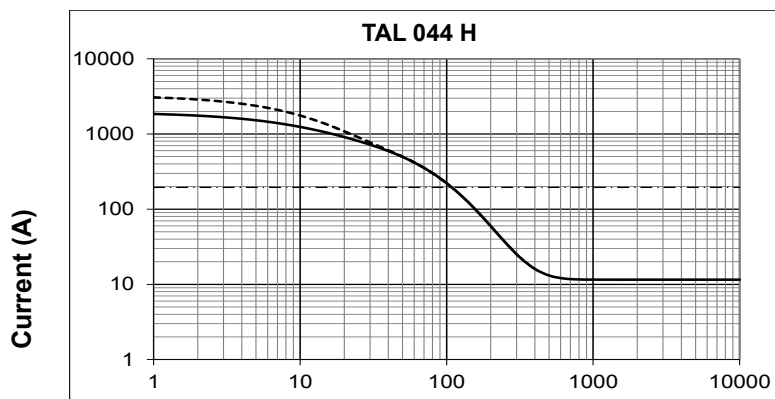

Symmetrical
Asymmetrical

Time (ms)

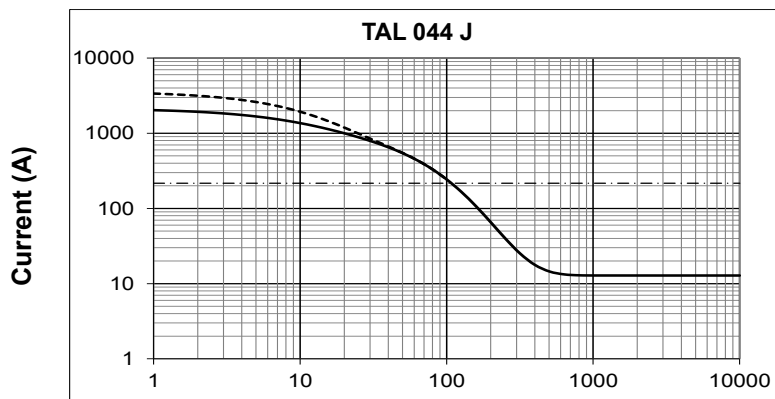

Symmetrical
Asymmetrical

Time (ms)

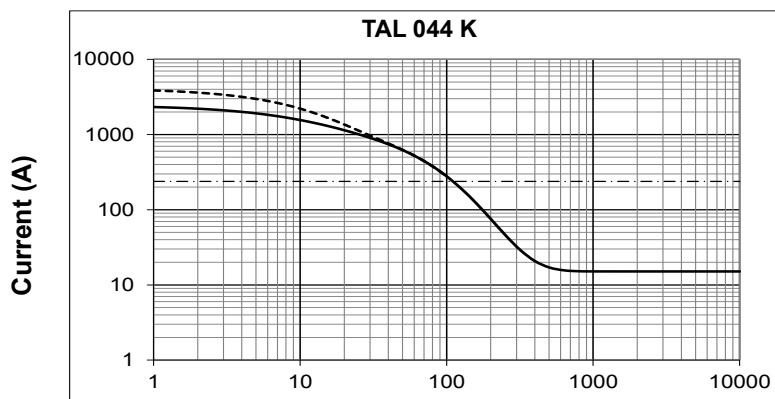

Symmetrical
Asymmetrical

Time (ms)

Influence due to short-circuit

Curves are based on a three-phase short-circuit.

For other types of short-circuit, use the following multiplication factors.

	3 - phase	2 - phase L / L	1 - phase L / N
Instantaneous (max.)	1	0.87	1.3
Continuous	1	1.5	2.2
Maximum duration (AREP/PMG)		1.5	

Low Voltage Alternators - 4 pole

TAL040 - TAL042 - TAL044 Singlephase 10,5 to 82 kVA - 50 Hz / 11.5 to 125 kVA - 60 Hz

General characteristics - Single phase

Insulation class	H	Excitation system	SHUNT
Winding pitch	2/3 (Winding M/M1)	AVR type	R120
Number of wires	4	Voltage regulation (*)	± 1 %
Protection	IP 23	Totale Harmonic distortion THD (**) in no-load:	< 3.5 % according to C.E.I.
Altitude	≤ 1000 m	Totale Harmonic distortion THD (**) in linear load:	< 5 % according to C.E.I.
Overspeed	2250 R.P.M.	Waveform: NEMA = TIF (**)	< 100
Air flow (m³/s)	50Hz : TAL040 : 0.06 - TAL042 : 0.10 - TAL044 : 0.25 60Hz : TAL040 : 0.07 - TAL042 : 0.13 - TAL044 : 0.30	(*) Steady state. (**) between phases η	

Ratings / Efficiencies - Single phase

kVA / kW - P.F. = 1								
Type	50 Hz - 1500 R.P.M.				60 Hz - 1800 R.P.M.			
Duty/T°C	Continuous / 40°C		Stand-by / 27°C		Continuous / 40°C		Stand-by / 27°C	
Class/T°K	H / 125°K		H / 163°K		H / 125°K		H / 163°K	
1 Phase serie	230V	η %	230V	η %	240V	η %	240V	η %
TAL040 C	10.5	80.2	11.4	78.9	11.5	80	12.5	79
TAL040 C1	12	82.4	13.2	81.5	13.5	81.7	15	80.8
TAL040 D	13.2	83.4	14.5	82.6	14.5	82.6	16	81.8
TAL040 E	14.5	84.2	16	83.5	15.8	83.5	17.4	82.8
TAL040 F	16	85.2	17.6	84.7	17.6	84.5	19.4	83.8
TAL042 A	18.2	85.7	20	84.7	23	86.3	25.3	85.7
TAL042 B	20.3	86.1	22.3	85.3	26	86.3	28.6	85.7
TAL042 C	22.4	87	24.6	86.4	28.8	87.2	31.6	86.6
TAL042 D	25	88.6	27.5	88.2	31.5	88.4	34.7	88.1
TAL042 E	28	88.1	30.8	87.6	36	87.9	39.6	87.4
TAL042 F	31.5	88.3	34.7	87.7	40	88.2	44	87.6
TAL042 G	35	88.5	38.5	88	47.2	88.1	51.9	87.9
TAL042 H	42	88.7	46.2	88.2	53	88.6	58.3	88.2
TAL044C	57	89	63	88.7	80	88	88	87.7
TAL044 D1	69	89.5	76	89.1	100	88	110	87.7
TAL044 E	-	-	-	-	115	88.7	127	88.2
TAL044 J	82	90.3	90	90	-	-	-	-
TAL044 K	-	-	-	-	125	89.7	138	89.4



Low Voltage Alternators - 4 pole

TAL040 - TAL042 - TAL044

TAL040 single bearing general arrangement

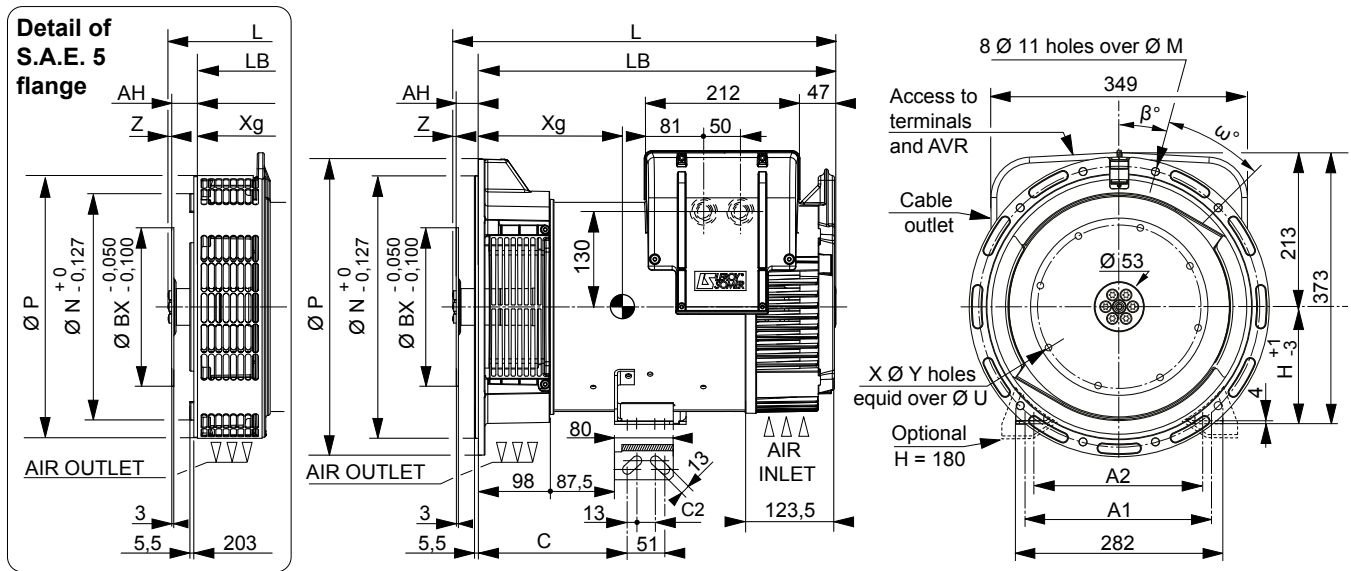

Dimensions (mm) and weight				
Type	L maxi	LB	Xg	Weight (kg)
TAL040 B	467	405	186	73
TAL040 C	467	405	186	73
TAL040 C1	467	407	196	80
TAL040 D	497	435	204	87
TAL040 E	497	435	221	92
TAL040 F	517	455	221	102

Shaft height (mm)		
H	Standard	Option
	160	180
Foot length		
C	203	238
C2	25	22
A1	254	279
A2	230	-

Coupling		
Flange	4	5
Flex plate	10	x
	8	x
	7 1/2	x
	6 1/2	x
	-	-

Flange (mm)					
S.A.E.	P	N	M	β°	ω°
5	358	314.32	333.38	22°30'	45°
4	408	361.95	381	15°	30°
-	-	-	-	-	-
-	-	-	-	-	-

Flex plate (mm)						
S.A.E.	BX	U	X	Y	AH	Z
10	314.32	295.28	8	11	53.8	0
8	263.52	244.48	6	11	62	0
7 1/2	241.3	222.25	8	9	30.2	4.5
6 1/2	215.9	200.02	6	9	30.2	4.5

Torsional analysis data

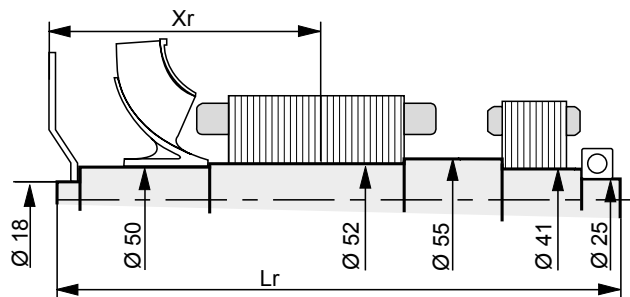

Centre of gravity: Xr (mm), Rotor length: Lr (mm), Weight: M (kg), Moment of inertia: J (kgm²): (4J = MD²)																
Type	Flex plate S.A.E. 6 1/2				Flex plate S.A.E. 7 1/2				Flex plate S.A.E. 8				Flex plate S.A.E. 10			
	Xr	Lr	M	J	Xr	Lr	M	J	Xr	Lr	M	J	Xr	Lr	M	J
TAL040 B	211.7	428	25.54	0.0779	211.7	428	25.7	0.0802	243.5	428	26	0.0847	238.3	428	26.5	0.0964
TAL040 C	211.7	428	25.54	0.0779	211.7	428	25.7	0.0802	243.5	428	26	0.0847	238.3	428	26.5	0.0964
TAL040 C1	221.7	428	27.95	0.0867	221.7	428	28.11	0.0890	253.5	428	28.41	0.0935	248.3	428	28.91	0.1052
TAL040 D	229.2	458	30.32	0.0936	229.2	458	30.48	0.0959	261	458	30.78	0.1004	255.8	458	31.28	0.1121
TAL040 E	236.7	458	32.23	0.1004	236.7	458	32.39	0.1027	268.5	458	32.69	0.1072	263.3	458	33.19	0.1189
TAL040 F	246.7	478	35.26	0.1102	246.7	478	35.42	0.1125	278.5	478	35.72	0.1170	273.3	478	36.22	0.1287

NOTE : Dimensions are for information only and may be subject to modifications. Contractuel 2D/3D drawings can be downloaded from the Leroy-Somer site. The torsional analysis of the transmission is imperative. All values are available upon request.

Low Voltage Alternators - 4 pole

TAL040 - TAL042 - TAL044

TAL042 single bearing general arrangement

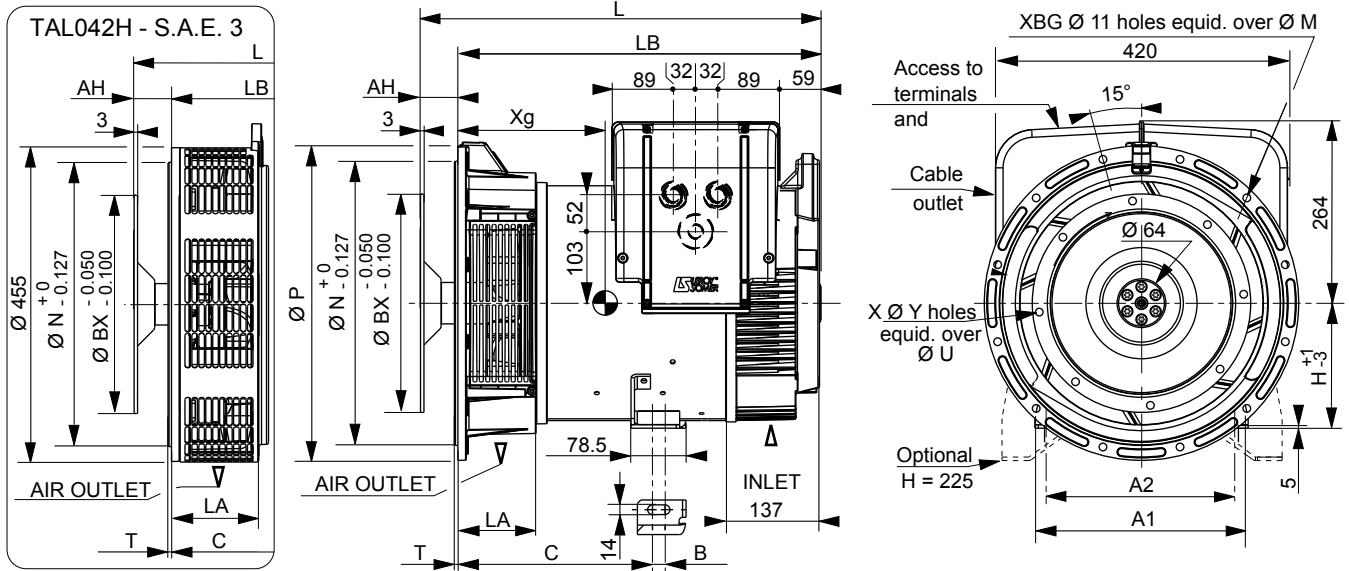

Dimensions (mm) and weight (kg)					Shaft height (mm)		Coupling		
Type	L	LB	Xg	Weight (kg)	Standard	Option	Flange		
TAL042 A	565	503	237	117	H	180	225		
TAL042 B	565	503	242	122	Feet length		11 1/2	x	-
TAL042 C	565	503	252	133	C	260	299 (A, B, C) / 321.5		
TAL042 D	610	548	275	165	B	18	8		
TAL042 E	610	548	275	165	A1	307	7 1/2		
TAL042 F	650	588	287	181	A2	279	356		
TAL042 G	650	588	295	186					
TAL042 H	662	622	310	187					

Flange (mm)							Flex plate (mm)					
S.A.E.	P	N	M	XBG	T	LA	S.A.E.	BX	U	X	Y	AH
4	406	361.95	381	12	6	122	11 1/2	352.42	333.38	8	11	39.6
3	452	409.58	428.62	12	5	112.5	10	314.32	295.28	8	11	53.8
-	-	-	-	-	-	-	8	263.52	244.48	6	11	62
							7 1/2	241.3	222.25	8	9	30.2

Torsional analysis data

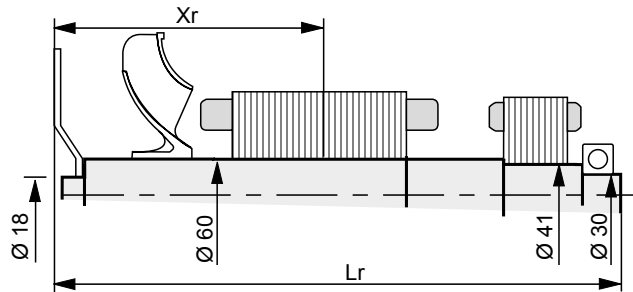

Centre of gravity: Xr (mm), Rotor length: Lr (mm), Weight: M (kg), Moment of inertia: J (kgm²): (4J = MD²)

Type	Flex plate S.A.E. 7 1/2				Flex plate S.A.E. 8				Flex plate S.A.E. 10				Flex plate S.A.E. 11 1/2			
	Xr	Lr	M	J	Xr	Lr	M	J	Xr	Lr	M	J	Xr	Lr	M	J
TAL042 A	279	526.2	45.36	0.2209	277	558	45.68	0.2246	274	549.8	46.13	0.2363	272	535.6	46.62	0.2843
TAL042 B	282	526.2	47.36	0.2337	280	558	47.68	0.2374	277	549.8	48.13	0.2491	274	535.6	48.62	0.2611
TAL042 C	287	526.2	51.41	0.2592	286	558	51.73	0.2629	283	549.8	52.18	0.2746	281	535.6	52.67	0.2866
TAL042 D	310	571.2	61.49	0.317	308	603	61.81	0.3207	306	594.8	62.26	0.3324	304	580.6	62.75	0.3444
TAL042 E	310	571.2	61.49	0.317	308	603	61.81	0.3207	306	594.8	68.18	0.3645	304	580.6	62.75	0.3444
TAL042 F	325	611.2	67.41	0.3491	323	643	67.73	0.3528	321	634.8	68.18	0.3645	319	620.6	68.67	0.3765
TAL042 G	330	611.2	70.42	0.3683	328	643	70.74	0.372	326	634.8	71.18	0.3837	324	620.6	71.68	0.3957
TAL042 H	344	641.2	77.49	0.4141	342	673	77.81	0.4178	340	664.8	78.25	0.4295	338	650.6	78.75	0.4415

NOTE : Dimensions are for information only and may be subject to modifications. Contractuel 2D/3D drawings can be downloaded from the Leroy-Somer site. The torsional analysis of the transmission is imperative. All values are available upon request.

Low Voltage Alternators - 4 pole

TAL040 - TAL042 - TAL044

TAL044 single bearing general arrangement

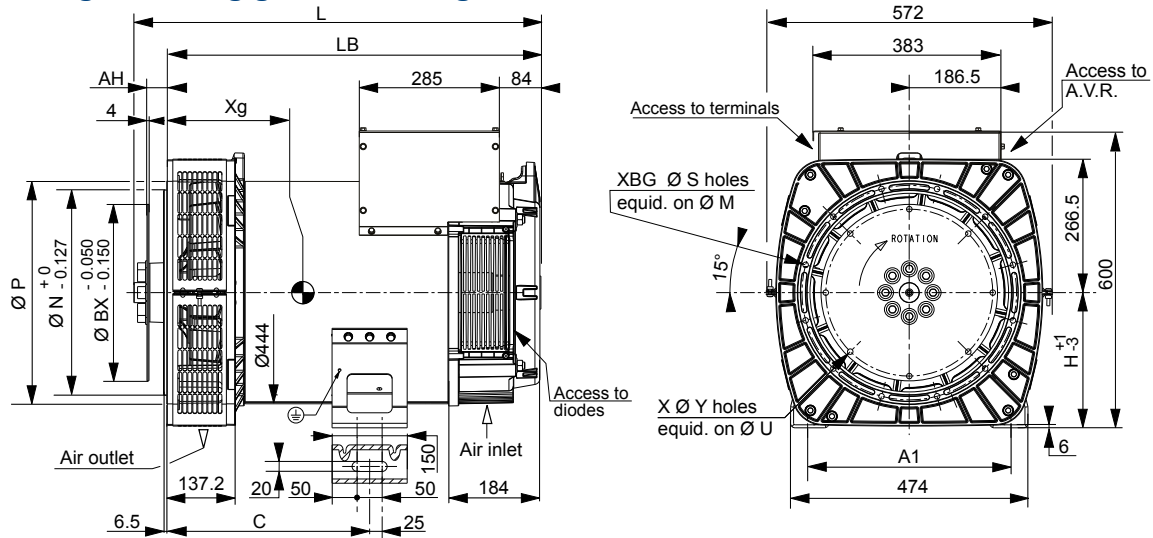

Dimensions (mm) and weight					Shaft height (mm)		Coupling	
Type	L	LB	Xg	Weight/kg	Standard	Option	Flange	3
TAL044 A	731	677	293	262	H	270	Flex plate	
TAL044 B	731	677	293	262	Foot length		11 1/2	x
TAL044 C	731	677	313	295	C	405	10	x
TAL044 D	731	677	313	295	A1	406	356	
TAL044 D1	731	677	313	295				
TAL044 E	801	747	353	368				
TAL044 H	801	747	353	368				
TAL044 J	801	747	365	398				
TAL044 K	841	787	383	433				

Flange (mm)						Flex plate (mm)					
S.A.E.	P	N	M	S	XBG	S.A.E.	BX	U	X	Y	AH
3	530	409.575	428.62	11	12	11 1/2	352.42	333.38	8	11	39.6
						10	314.32	295.28	8	11	53.8

Torsional analysis data

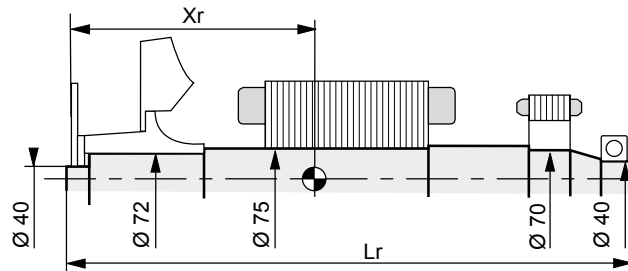

Centre of gravity: X_r (mm), Rotor length: L_r (mm), Weight: M (kg), Moment of inertia: J (kgm^2): ($4J = MD^2$)

Type	Flex plate S.A.E. 10				Flex plate S.A.E. 11 1/2				
	X_r	L_r	M	J	X_r	L_r	M	J	
TAL044 A	329.6	729	107.7	0.754	314.6	729	107.1	0.769	
TAL044 B	329.6	729	107.7	0.754	314.6	729	107.1	0.769	
TAL044 C	363	729	121.6	0.878	348.8	729	121	0.893	
TAL044 D	363	729	121.6	0.878	348.8	729	121	0.893	
TAL044 D1	363	729	121.6	0.878	348.8	729	121	0.893	
TAL044 E	397.7	799	154.3	1.152	383.5	799	153.7	1.167	
TAL044 H	397.7	799	154.3	1.152	383.5	799	153.7	1.167	
TAL044 J	396.7	799	166.1	1.259	382.5	799	165.5	1.214	
TAL044 K	416.9	839	181.5	1.394	402.7	839	180.9	1.409	

NOTE : Dimensions are for information only and may be subject to modifications. Contractuel 2D/3D drawings can be downloaded from the Leroy-Somer site. The torsional analysis of the transmission is imperative. All values are available upon request.

Low Voltage Alternators - 4 pole

TAL040 - TAL042 - TAL044

Low Voltage Alternators - 4 pole

TAL040 - TAL042 - TAL044

Leroy-Somer™

www.leroy-somer.com/epg

© Emerson 2016. The information contained in this brochure is for guidance only and does not form part of any contract. The accuracy cannot be guaranteed as Emerson have an ongoing process of development and reserve the right to change the specification of their products without notice.

Moteurs Leroy-Somer SAS. Headquarters: Bd Marcellin Leroy, CS 10015, 16915 Angoulême Cedex 9, France. Share Capital: 65 800 512 €, RCS Angoulême 338 567 258.