

## Low Voltage Alternators - 4 pole

**LSA 52.3**

Installation and maintenance

Leroy-Somer™

  
**EMERSON™**

# LSA 52.3

## Low Voltage Alternators - 4 pole

**This manual concerns the alternator which you have just purchased.  
We wish to draw your attention to the contents of this maintenance manual.**

### SAFETY MEASURES

Before using your machine for the first time, it is important to read the whole of this installation and maintenance manual.

All necessary operations and interventions on this machine must be performed by a qualified technician.

Our technical support service will be pleased to provide any additional information you may require.

The various operations described in this manual are accompanied by recommendations or symbols to alert the user to the potential risk of accidents. It is vital that you understand and take notice of the different warning symbols used.

#### WARNING

**Warning symbol for an operation capable of damaging or destroying the machine or surrounding equipment.**



**Warning symbol for general danger to personnel.**



**Warning symbol for electrical danger to personnel.**

### WARNING SYMBOLS

We wish to draw your attention to the following 2 safety measures which must be complied with:

**a) During operation, do not allow anyone to stand in front of the air outlet guards, in case anything is ejected from them.**

**b) Do not allow children younger than 14 to go near the air outlet guards.**

A set of self-adhesive stickers depicting the various warning symbols is included with this maintenance manual. They should be positioned as shown in the drawing below once the machine has been fully installed.

### WARNING

**The alternators must not be put into service until the machines in which they are to be incorporated have been declared compliant with Directives EC and plus any other directives that may be applicable.**

**This manual is to be given to the end user.**

**The range of electric alternators and their derivatives, manufactured by us or on our behalf, comply with the technical requirements of the customs Union directives (EAC).**

© - We reserve the right to modify the characteristics of its products at any time in order to incorporate the latest technological developments. The information contained in this document may therefore be changed without notice.

This document may not be reproduced in any form without prior authorization.

All brands and models have been registered and patents applied for.

# LSA 52.3

## Low Voltage Alternators - 4 pole

### CONTENTS

<b>1 - RECEIPT .....</b>	<b>4</b>
1.1 - Standards and safety measures .....	4
1.2 - Inspection .....	4
1.3 - Identification .....	4
1.4 - Storage .....	4
1.5 - Applications .....	4
1.6 - Contraindications to use .....	4
 <b>2 - TECHNICAL CHARACTERISTICS .....</b>	 <b>5</b>
2.1 - Electrical characteristics .....	5
2.2 - Mechanical characteristics .....	5
 <b>3 - INSTALLATION .....</b>	 <b>6</b>
3.1 - Assembly .....	6
3.2 - Checks prior to first use .....	6
3.3 - Terminal connection diagrams .....	7
3.4 - Commissioning .....	10
3.5 - Setting up .....	10
 <b>4 - SERVICING - MAINTENANCE .....</b>	 <b>11</b>
4.1 - Safety measures .....	11
4.2 - Routine maintenance .....	11
4.3 - Bearings .....	12
4.4 - Mechanical defects .....	12
4.5 - Electrical faults .....	13
4.6 - Dismantling, reassembly .....	15
4.7 - Installation & maintenance of the PMG .....	17
4.8 - Table of characteristics .....	17-18
 <b>5 - SPARE PARTS .....</b>	 <b>19</b>
5.1 - First maintenance parts .....	19
5.2 - Technical support service .....	19
5.3 - Accessories .....	19
5.4 - Exploded views, parts list and tightening torque .....	20

**Disposal and recycling instructions**

**EC declaration of incorporation**

# LSA 52.3

## Low Voltage Alternators - 4 pole

### 1 - RECEIPT

#### 1.1 - Standards and safety measures

Our alternators comply with most international standards.  
See the EC Declaration of Incorporation on the last page.

#### 1.2 - Inspection

On receipt of your alternator, check that it has not suffered any damage in transit. If there are obvious signs of knocks, contact the transporter (you may be able to claim on their insurance) and after a visual check, turn the machine by hand to detect any malfunction.

#### 1.3 - Identification

The alternator is identified by means of a nameplate fixed on the machine (see drawing).

Make sure that the nameplate on the machine conforms to your order.

So that you can identify your alternator quickly and accurately, we suggest you fill in its specifications on the nameplate below.

#### 1.4 - Storage

Prior to commissioning, machines should be stored :

- away from humidity (< 90%); after a long period of storage, check the machine insulation. To prevent the bearings from becoming marked, do not store in an environment with significant vibration.

#### 1.5 - Application

These alternators are mainly designed to produce electricity in the context of applications involving the use of generators.

#### 1.6 - Contraindications to use

Use of the machine is restricted to operating conditions (environment, speed, voltage, power, etc) compatible with the characteristics indicated on the nameplate.

Puisissance Power rating		Cos $\Phi$ Rend Eff. %		$\Delta$ A	
tr/mn RPM		Ph		Isolation Insulation Cl.	
Service Duty		Echauffement Temperature rise		PdB WP	
Régulat. A.V.R. Date		Excitation A vide No load		En charge Rated load	
Masse Weight		Rit côté entraînement DE BRG			
Quant.		Rit côté opposé NDE BRG			
Periodicité de graissage Grease every		Avec With			
Graisser en rotation Regrease in running		Ou tous les 6 mois Or every 6 months		Ou graissage équivalente - Or any equivalent grease Graisser à mise en service - Regrease at the start up	
<b>ALTERNATEUR</b>		<b>CE</b>		<b>IEC 34 A.C. GENERATOR</b>	
		PS 003 0367			
Made in France		MOTEURS LEROY- SOMER - DPT. ACEO 45005 ORLEANS CEDEX 1 (FRANCE)			

# LSA 52.3

## Low Voltage Alternators - 4 pole

### 2 - TECHNICAL CHARACTERISTICS

#### 2.1 - Electrical characteristics

This alternator is a machine without sliprings or revolving field brushes, wound as "2/3 pitch"; 6 wire, with class H insulation and a field excitation system available in either AREP or "PMG" version (see diagrams and AVR maintenance manual).

##### • Options

- Stator temperature detection sensors
- Bearing sensors
- Space heaters
- Protection or measurement current transformer (C.T.)

In order to conform to standard EN 61000-6-3, EN 61000-6-2, EN 55011, the R 791 interference suppression kit is needed.

#### 2.2 - Mechanical characteristics

- Steel frame
- Cast iron end shields

- Single bearing standard alternator: regreasable roller bearing
- Double bearing standard alternator: regreasable NDE roller bearing and DE ball bearing
- Single and double bearing marine alternator or insulated bearing: regreasable NDE ball bearing
- Mounting arrangement  
IM 1201 (MD 35): Single-bearing with feet and SAE flanges/coupling discs  
IM 1001 (B 34): Double bearing with SAE flange and standard cylindrical shaft extension
- Drip-proof machine, self-cooled
- Degree of protection: IP 23

##### • Options

- Protection against harsh environments
  - Air inlet and outlet filter: IP 44
- To prevent excessive temperature rise caused by clogged filters, it is advisable to monitor the stator winding with thermal sensors (PT100).

#### AREP+PMI system with D510C (or option R449)

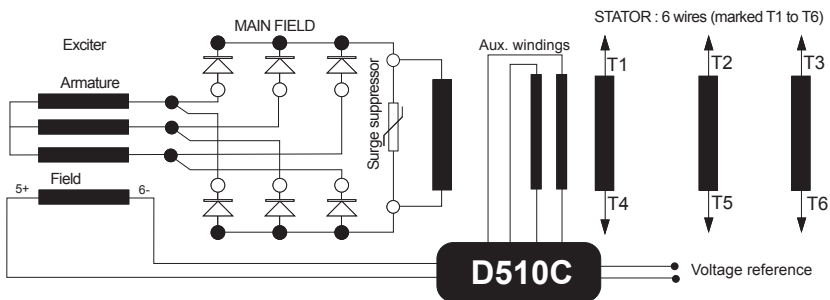

#### PMG system with D510C (or option R449)

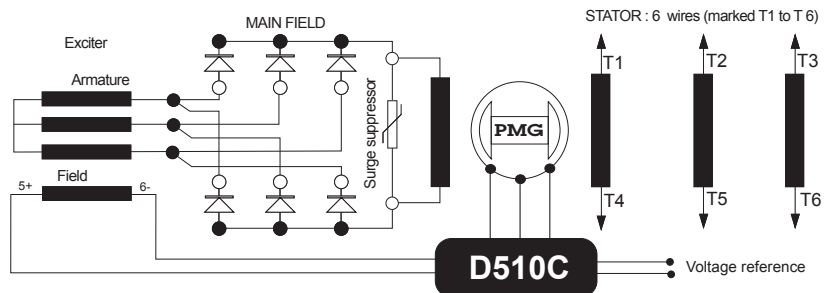

# LSA 52.3

## Low Voltage Alternators - 4 pole

### 3 - INSTALLATION

Personnel undertaking the various operations indicated in this section must wear personal protective equipment appropriate for mechanical and electrical hazards.

#### 3.1 - Assembly



All mechanical handling operations must be undertaken using suitable equipment and the machine must be horizontal. Check how much the machine weighs (see 4.8) before choosing the lifting tool.

During this operation, do not allow anyone to stand under the load.

##### • Handling

The generously-sized lifting rings are for handling the alternator alone. They must not be used to lift the genset. The choice of lifting hooks or handles should be determined by the shape of these rings. Choose a lifting system which respects the integrity and the environment of the machine.

During this operation, do not allow anyone to stand under the load.

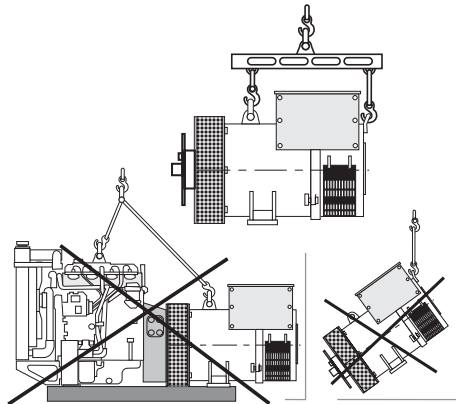

##### • Single-bearing coupling

Before coupling, check the compatibility between the alternator and the engine by performing:

- undertaking a torsional analysis of the transmission (alternators data are available on request),
- checking the dimensions of the flywheel and its housing, the flange, coupling discs and offset.

#### WARNING

When coupling the alternator to the prime mover, do not use the fan to turn the alternator or rotor.

The holes of the coupling discs should be aligned with the flywheel holes by cranking the engine.

Make sure the machine is securely bedded in position during coupling.

Check that there is lateral play on the crankshaft.

##### • Double-bearing coupling

- Semi-flexible coupling

Careful alignment of the machines is recommended, checking that the lack of concentricity and parallelism of both parts of the coupling do not exceed 0.1 mm.

**This alternator has been balanced with a 1/2 key.**

##### • Location

The room where the alternator is placed must be ventilated to ensure that the ambient temperature cannot exceed the data on the nameplate.

#### 3.2 - Checks prior to first use

##### • Electrical checks



Under no circumstances should an alternator, new or otherwise, be operated if the insulation is less than 1 megohm for the stator and 100,000 ohms for the other windings.

## LSA 52.3

### Low Voltage Alternators - 4 pole

There are 2 possible methods for restoring the above minimum values.

a) Dry out the machine for 24 hours in a drying oven at a temperature of 110 °C (without the regulator).

b) Blow hot air into the air intake, having made sure that the machine is rotating with the exciter field disconnected.

#### **Note : Prolonged standstill**

In order to avoid these problems, we recommend the use of space heaters, as well as turning over the machine from time to time. Space heaters are only really effective if they are working continuously while the machine is stopped.

### **WARNING**

**Ensure that the alternator has the degree of protection matching the defined environmental conditions.**

#### **• Mechanical checks**

Before starting the machine for the first time, check that:

- all fixing screws are tight,
- the length of screw and the tightening torque are correct,
- the cooling air is drawn in freely,
- the protective grilles and housing are correctly in place,
- the standard direction of rotation is clockwise as seen from the shaft end (phase rotation in order 1 - 2 - 3).

For anti-clockwise rotation, swap 2 and 3.

- the winding connection corresponds to the site operating voltage (see section 3.3).

#### **3.3 - Terminal connection diagrams**

To modify the connection, change the position of the stator cables on the terminals. The winding code is specified on the nameplate.



**Any intervention on the alternator terminals during reconnection or checks should be performed with the machine stopped.**

**In no case should the internal connections in the terminal box be subjected to stresses due to cables connected by the user.**

# LSA 52.3

## Low Voltage Alternators - 4 pole

### • Terminal connection

Connection code	Voltage L-L													
<div style="display: flex; align-items: center;"> <div style="margin-right: 20px;"> <p style="font-size: 24px; border: 1px solid black; border-radius: 50%; padding: 5px; display: inline-block;">D</p> <p>Star 3 PH</p> </div> </div>	<table border="1" style="margin: auto; border-collapse: collapse;"> <thead> <tr> <th style="width: 15%;">Winding</th> <th style="width: 15%;">50 Hz</th> <th style="width: 15%;">60Hz</th> </tr> </thead> <tbody> <tr> <td>6 S</td> <td>380 - 415</td> <td>380 - 480</td> </tr> <tr> <td>8 S</td> <td>347</td> <td>380 - 416</td> </tr> <tr> <td colspan="2">AVR connector</td> <td>0 - 380 V</td> </tr> </tbody> </table>	Winding	50 Hz	60Hz	6 S	380 - 415	380 - 480	8 S	347	380 - 416	AVR connector		0 - 380 V	<p>Factory connection</p>
Winding	50 Hz	60Hz												
6 S	380 - 415	380 - 480												
8 S	347	380 - 416												
AVR connector		0 - 380 V												



## LSA 52.3

### Low Voltage Alternators - 4 pole

#### • Connection checks



**Electrical installations must comply with the current legislation in force in the country of use.**

Check that:

- The residual circuit-breaker conforms to legislation on protection of personnel, in force in the country of use, and has been correctly installed on the alternator power output as close as possible to the alternator. (In this case, disconnect the wire of the interference suppression module linking the neutral).
- Any protection devices in place have not been tripped.
- If there is an external AVR, the connections between the alternator and the cabinet are made in accordance with the connection diagram.
- There is no short-circuit phase-phase or phase-neutral between the alternator output terminals and the generator set control cabinet (part of the circuit not protected by circuitbreakers or relays in the cabinet).
- The machine should be connected with the busbar separating the terminals as shown in the terminal connection diagram.



- The alternator earth terminal inside the terminal box is connected to the electrical earth circuit

- The earth terminal is connected to the frame.

The connections inside the terminal box must never be subjected to stress due to cables connected by the user.



## LSA 52.3

### Low Voltage Alternators - 4 pole

#### 3.4 - Commissioning



**The machine can only be started up and used if the installation is in accordance with the regulations and instructions defined in this manual.**

The machine is tested and set up at the factory. When first used with no load, make sure that the drive speed is correct and stable (see the nameplate). With the regreasable bearing option, we recommend greasing the bearings at the time of commissioning (see section 4.3).

On application of the load, the machine should achieve its rated speed and voltage; however, in the event of abnormal operation, the machine setting can be altered (follow the adjustment procedure in section 3.5). If the machine still operates incorrectly, the cause of the malfunction must be located (see section 4.5).

#### 3.5 - Setting up



**The various adjustments during tests must be made by a qualified engineer. Ensure that the drive speed specified on the nameplate is reached before commencing adjustment.**

**After operational testing, replace all access panels or covers.**

**The AVR is used to make any adjustments to the machine.**

## LSA 52.3

### Low Voltage Alternators - 4 pole

#### 4 - SERVICING - MAINTENANCE

##### 4.1 - Safety measures

Servicing or troubleshooting must be carried out strictly in accordance with instructions so as to avoid the risk of accidents and to maintain the machine in its original state.



All such operations performed on the alternator should be undertaken by personnel trained in the commissioning, servicing and maintenance of electrical and mechanical components, who must wear personal protective equipment appropriate for mechanical and electrical hazards.

Before any intervention on the machine, ensure that it cannot be started by a manual or automatic system and that you have understood the operating principles of the system.



**Warning :** During and after running, the alternator will reach temperatures hot enough to cause injury, such as burns.

##### 4.2 - Routine maintenance

###### • Checks after start-up

After approximately 20 hours of operation, check that all fixing screws on the machine are still tight, plus the general state of the machine and the various electrical connections in the installation.

###### • Electrical servicing

Commercially-available volatile degreasing agents can be used.

#### WARNING

**Do not use:** trichlorethylene, perchlorethylene, trichloroethane or any alkaline products.



**These operations must be performed at a cleaning station, equipped with a vacuum system that collects and flushes out the products used.**

The insulating components and the impregnation system are not at risk of damage from solvents. Avoid letting the cleaning product run into the slots.

Apply the product with a brush, sponging frequently to avoid accumulation in the housing. Dry the winding with a dry cloth. Let any traces evaporate before reassembling the machine.

###### • Mechanical servicing

#### WARNING

**Cleaning the machine using water or a highpressure washer is strictly prohibited. Any problems arising from such treatment are not covered by our warranty.**

Degreasing: Use a brush and detergent (suitable for paintwork).

Dusting: Use an air gun.

If the machine is fitted with air inlet and outlet filters, the maintenance personnel should clean them routinely at regular intervals. In the case of dry dust, the filter can be cleaned using compressed air and/or replaced if it is clogged.

After cleaning the alternator, it is essential to check the winding insulation (see sections 3.2 and 4.5).

## LSA 52.3

### Low Voltage Alternators - 4 pole

#### 4.3 - Bearings

As an standard, the bearings are regreasable	Regreasing interval: 1700 hrs of operation DE bearing: Amount of grease: 70 gr NDE bearing: Amount of grease: 35 gr
Standard grease	LITHIUM - standard - NLGI 3
Grease used in the factory	MOBIL POLYREX™ EM : grade NLGI 2
 <b>It is imperative to lubricate the alternator during operation and on first use. Before using another grease, check for compatibility with the original one.</b>	

#### 4.4 - Mechanical defects

Fault		Action
Bearing	Excessive overheating of one or both bearings (bearing temperature 80°C above the ambient temperature)	<ul style="list-style-type: none"> <li>- If the bearing has turned blue or if the grease has turned black, change the bearing.</li> <li>- Bearing not fully locked (abnormal play in the bearing cage)</li> <li>- End shields incorrectly aligned</li> </ul>
Abnormal temperature	Excessive overheating of alternator frame (more than 40° C above the ambient temperature)	<ul style="list-style-type: none"> <li>- Air flow (inlet-outlet) partially clogged or hot air is being recycled from the alternator or engine</li> <li>- Alternator operating at too high a voltage (&gt;105% of Un on load)</li> <li>- Alternator overloaded</li> </ul>
Vibrations	Too much vibration	<ul style="list-style-type: none"> <li>- Misalignment (coupling)</li> <li>- Defective mounting or play in coupling</li> <li>- Rotor balancing fault (Engine - Alternator)</li> </ul>
	Excessive vibration and humming noise coming from the machine	<ul style="list-style-type: none"> <li>- Phase imbalance</li> <li>- Stator short-circuit</li> </ul>
Abnormal noise	Alternator damaged by a significant impact, followed by humming and vibration	<ul style="list-style-type: none"> <li>- System short-circuit</li> <li>- Misparalleling</li> </ul> <p>Possible consequences</p> <ul style="list-style-type: none"> <li>- Broken or damaged coupling</li> <li>- Broken or bent shaft end</li> <li>- Shifting and short-circuit of main field</li> <li>- Fan fractured or coming loose on shaft</li> <li>- Irreparable damage to rotating diodes/AVR, surge suppressor</li> </ul>

## LSA 52.3

### Low Voltage Alternators - 4 pole

#### 4.5 - Electrical faults

Fault	Action	Effect	Check/Cause
No voltage at no load on start-up	Connect a new battery of 4 to 12 volts to terminals E- and E+, respecting the polarity, for 2 to 3 seconds	The alternator builds up and its voltage is still correct when the battery is removed	- Lack of residual magnetism
		The alternator builds up but its voltage does not reach the rated value when the battery is removed	- Check the connection of the voltage reference to the AVR - Faulty diodes - Armature short-circuit
		The alternator builds up but its voltage disappears when the battery is removed	- Faulty AVR - Field windings disconnected - Main field winding open circuit - check the resistance
Voltage too low	Check the drive speed	Correct speed	Check the AVR connections (AVR may be faulty) - Field windings short-circuited - Rotating diodes burnt out - Main field winding short-circuited - Check the resistance
		Speed too low	Increase the drive speed (Do not touch the AVR voltage pot. (P2) before running at the correct speed.)
Voltage too high	Adjust AVR voltage potentiometer	Adjustment ineffective	- Faulty AVR - 1 faulty diode
Voltage oscillations	Adjust AVR stability potentiometer	If no effect : try normal / fast recovery modes (ST2)	- Check the speed : possibility of cyclic irregularity - Loose connections - Faulty AVR - Speed too low when on load (or LAM set too high)
Voltage correct at no load and too low when on load	Run at no load and check the voltage between E+ and E- on the AVR	Voltage between E+ and E- AREP / PMG < 10V	- Check the speed (or LAM set too high)
		Voltage between E+ and E- AREP / PMG > 15V	- Faulty rotating diodes - Short-circuit in the main field. Check the resistance - Faulty exciter armature.
Voltage disappears during operation	Check the AVR, the surge suppressor, the rotating diodes, and replace any defective components	The voltage does not return to the rated value.	- Exciter winding open circuit - Faulty exciter armature - Faulty AVR - Main field open circuit or short-circuited

## LSA 52.3

### Low Voltage Alternators - 4 pole

#### • Checking the winding

You can check the winding insulation by performing a high voltage test. In this case, you must disconnect all AVR wires.

#### WARNING

**Damage caused to the AVR in such conditions is not covered by our warranty.**

#### • Checking the diode bridge

A diode in good working order should allow the current to flow only in the anode-to-cathode direction.

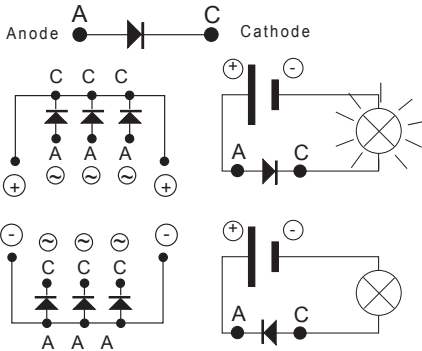

#### • Checking the windings and rotating diodes using separate excitation



During this procedure, make sure that the alternator is disconnected from any external load and inspect the terminal box to check that the connections are fully tightened.

- 1) Stop the unit, disconnect and isolate the AVR wires.
- 2) There are two ways of creating an assembly with separate excitation.

**Assembly A:** Connect a 12 V battery in series with a rheostat of approximately 50 ohms - 300 W and a diode on both exciter field wires (5+) and (6-).

ASSEMBLY A

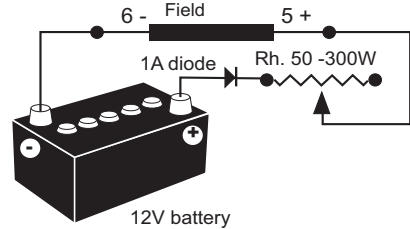

**Assembly B:** Connect a “Variac” variable power supply and a diode bridge on both exciter field wires (5+) and (6-).

Both these systems should have characteristics which are compatible with the field excitation power of the machine (see the nameplate).

3) Run the unit at its rated speed.

4) Gradually increase the exciter field current by adjusting the variac or the variac and measure the output voltages on L1 - L2 - L3, checking the excitation voltage and current at no load (see the machine nameplate or ask for the factory test report). When the output voltage is at its rated value and balanced within 1% for the rated excitation level, the machine is in good working order. The fault therefore comes from the AVR or its associated wiring (ie. sensing, auxiliary windings).

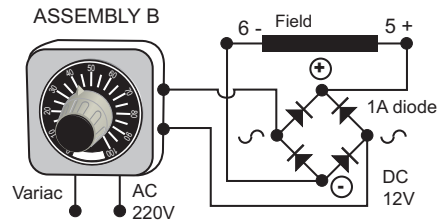

## LSA 52.3

### Low Voltage Alternators - 4 pole

#### 4.6 - Dismantling, reassembly

During the warranty period, this operation should only be carried out in an approved workshop or in our factory, otherwise the warranty may be invalidated.

Whilst being handled, the machine should remain horizontal (rotor not locked in position). Check how much the machine weighs before choosing the lifting method.

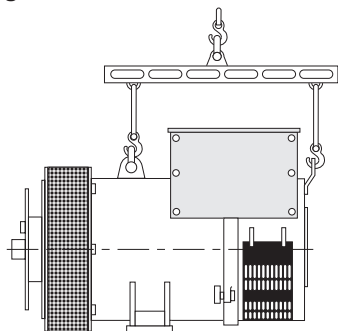

#### • Tools required

To fully dismantle the alternator, we recommend using the tools listed below :

- 1 ratchet spanner + extension
- 1 torque wrench
- 1 set of flat spanners : 8 mm, 10 mm, 18 mm
- 1 socket set : 8, 10, 13, 16, 18, 21, 24, 30 mm
- 1 socket with male ferrule: 5 mm
- 1 puller

#### • Screw tightening torque

See section 5.4.

#### • Access to diodes

- Open the air intake grille (51).
- Disconnect the diodes.
- Disconnect the diodes using an ohmmeter or a battery lamp.
- Remove the surge suppressor (347).
- Remove the 6 "H" mounting nuts for the diode bridges on the support.
- Change the fitted caps, respecting the polarity.

#### • Access to connections and the regulation system

Access directly by removing the box lid (48) or the AVR access door (466).

#### • Replacing the NDE bearing

- Remove the air intake grille (51).
- Remove the lid of the protective cover (48) and the side panels (366) and (367).
- Remove the hook (21) and the cover rear panel (365).
- Fit a M10 lifting ring (weight to handle: 300kg) on both top sides of the endshield in the tapping provided for this purpose.
- Disconnect the exciter wires (5+,6-).
- Remove the screws (72) from the inner bearing cap (78).
- Remove the screws (37).
- Remove the shield (36).
- Take out the antifriction bearing (70) using a puller with a central screw (see drawing below).

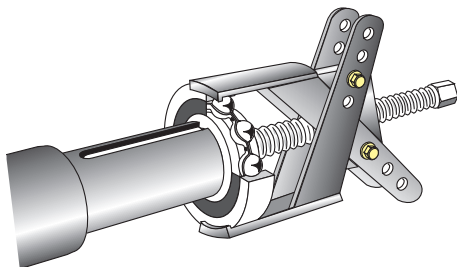

- Fit the new antifriction bearing onto the shaft after heating it by induction to approximately 80 °C.
- Mount the new preloading (wavy) washer (79) in the shield (36).
- Screw a threaded rod into the inner bearing cap (78).
- Refit the end shield on the machine using a dowel and nut in the shaft extension (see drawing).

## LSA 52.3

### Low Voltage Alternators - 4 pole

- Slide the threaded rod into the shield hole to make it easier to assemble (see diagram).

#### Ball single bearing

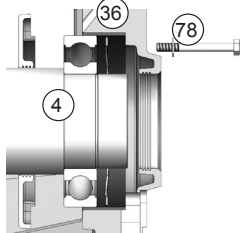

#### Ball double bearing

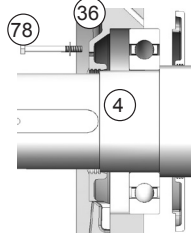

#### Roller single bearing

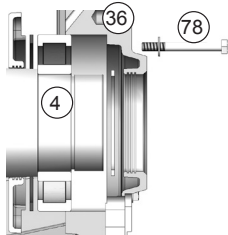

#### Roller double bearing

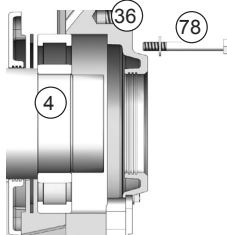

- Fit a inner bearing cap screw (78), remove the threaded rod, fit the other screws and tighten up the assembly.

- Tighten the shield screws (37).
- Reconnect exciter field wires E+, E-.
- Finish reassembling the cover.

### WARNING

**When dismantling the shields, you will need to change the antifriction bearings and the preloading (wavy) washer.**

#### • Replacing the DE bearing

- Remove the air outlet grille (33).
- Remove the screws (31) from the DE shield and the 4 screws (62) from the inner bearing retainer.
- Remove the shield (30).
- Take out the ball bearing (60) using a puller with a central screw.
- Fit the new bearing, after heating it by induction to approximately 80 °C.
- Screw two threaded rods into the inner bearing cap (68).
- Refit the shield (30) on the machine.

- Slide the threaded rods into the shield holes to make it easier to assemble (see basic diagram).

- Tighten the bottom inner bearing cap screws (78), remove the threaded rod and fit the other screws.
- Tighten the shield screws (31).
- Refit the air outlet grille (33).

#### • Dismantling the rotor assembly

- Remove the NDE shield (36).
- Remove the DE shield (30) if it is a twin-bearing machine.
- Support the DE rotor (4) with a strap or with a support constructed in accordance with the following drawing.
- Move the strap as the rotor moves in order to distribute the weight evenly over it.

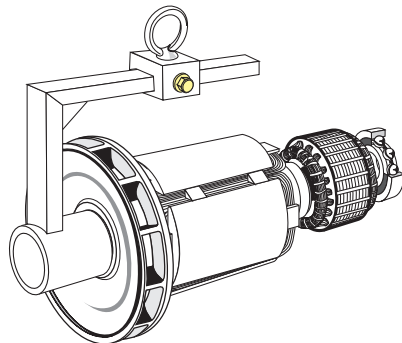

### WARNING

**When dismantling the rotor involves changing parts or rewinding, the rotor must be rebalanced.**



## LSA 52.3

### Low Voltage Alternators - 4 pole

#### • Reassembling the machine

- Mount the rotor (4) in the stator (1) (see drawing above) taking care not to knock the windings.

- Slide the threaded rod into the shield hole to make it easier to assemble (see diagram).

- Fit an inner bearing cap screw (78), remove the threaded rod, fit the other screw and tighten up the assembly.

- Tighten the shield screws (37).

- Reconnect exciter field wires E+, E-.

- Finish reassembling the cover.

- Refit the flange (30) on the stator (1).

- Tighten the screws (31).

If using a twin-bearing machine:

- Finish reassembling the cover.

- Screw a threaded rod into the inner bearing cap (68).

- Refit the shield (30) on the machine.

- Slide the threaded rod into the shield hole to make it easier to assemble (see diagram).

- Fit the inner bearing cap screws (68), remove the threaded rod, fit the other screw and tighten up the assembly.

- Tighten the shield screws (31).

- Refit the air outlet grille (33).

- Check that the machine assembly is correctly mounted and that all screws are tightened.

#### • Dismantling and reassembly of the filters

- Remove the grille (417) then take out the filter (418). Change the filter if necessary; please refer to section 4.2 for cleaning the filter.

To replace, follow the instructions in reverse order.

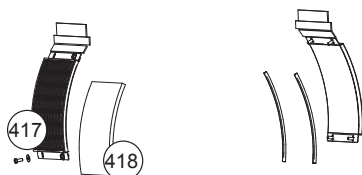

NDE filter

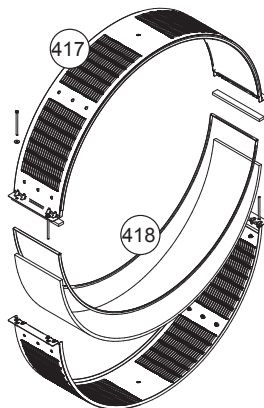

DE filter

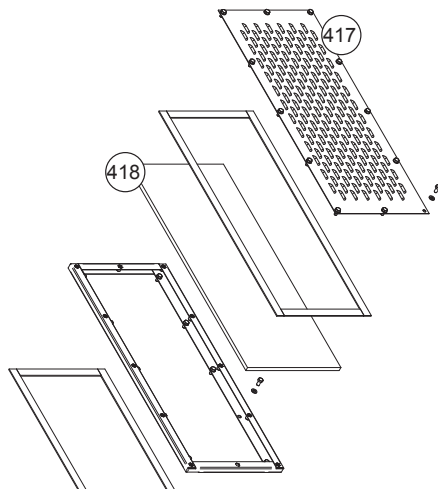

Terminal box filter

#### 4.7 - Installation and maintenance of the PMG

The PMG reference is : PMG 6.

See the PMG manual ref : 4211.

#### 4.8 - Table of characteristics

Table of average values.

Alternator - 4 poles - 50 Hz - Standard winding 400V.

## LSA 52.3

### Low Voltage Alternators - 4 pole

The voltage and current values are given for no-load operation and operation at rated load with separate field excitation. All values are given at  $\pm 10\%$  and may be changed without prior notification (for exact values, consult the test report).

#### • Average values

##### Resistances at 20°C ( $\Omega$ )

Type	L/N stator	Rotor	Exciter field	Armature
S5-S6	0.0020	0.35	8.7	0.020
S7	0.0016	0.37	8.7	0.020
L9	0.0012	0.42	8.7	0.020
L12	0.0010	0.48	8.7	0.020

##### Resistance of AREP auxiliary windings at 20°C ( $\Omega$ )

Type	Auxil wdg: X1, X2	Auxil wdg: Z1, Z2
S5-S6	0.1	0.16
S7	0.08	0.16
L9	0.09	0.13
L12	0.06	0.14

##### Field excitation current $i_{exc}$ (A)

Symbols: « $i_{exc}$ »: excitation current of the exciter field.

Type	No load	At rated load
S5	1.1	4.8
S6	1.1	5.1
S7	1.2	5
L9	1.2	4.7
L12	1.2	4.3

For 60 Hz machines, the « $i_{exc}$ » values are approximately 5 to 10% lower.

#### • Voltage of auxiliary windings at no load

Type	Auxil wdg: X1, X2	Auxil wdg: Z1, Z2
50 Hz	100V	10V
60 Hz	120V	12V

#### • Table of weights

(values given for information only)

Type	Total weight (kg)	Rotor (kg)
S5-S6	3740	1420
S7	3980	1460
L9	4470	1640
L12	4960	1810



**After operational testing, it is essential to replace all access panels or covers.**

## LSA 52.3

### Low Voltage Alternators - 4 pole

## 5 - SPARE PARTS

### 5.1 - First maintenance parts

Emergency repair kits are available as an option.

They contain the following items :

<b>Emergency kit AREP</b>	<b>ALT 523 KS 001</b>
AVR R 449	-
Diode bridge assembly	-
Surge suppressor	-
<b>Emergency kit AREP</b>	<b>ALT 523 KS 002</b>
AVR D 510C	-
Diode bridge assembly	-
Surge suppressor	-
<b>Single-bearing kit</b>	<b>ALT 523 KB 002</b>
Non drive end bearing	-
«O» ring	-
Preloading (wavy) washer	-
<b>Double-bearing kit</b>	<b>ALT 523 KB 001</b>
Non drive end bearing	-
Drive end bearing	-
«O» ring	-
Preloading (wavy) washer	-

### 5.2 - Technical support service

Our technical support service will be pleased to provide any additional information you may require.

When ordering spare parts, you should indicate the complete machine type, its serial number and the information given on the nameplate.

Address your enquiry to your usual contact.

Part numbers should be identified from the exploded views and their description from the parts list.

Our extensive network of service centres can dispatch the necessary parts without delay.

To ensure correct operation and the safety of our machines, we recommend the use of original manufacturer spare parts.

In the event of failure to comply with this advice, the manufacturer cannot be held responsible for any damage.



**After operational testing, it is essential to replace all access panels or covers.**

### 5.3 - Accessories

#### • Space heater when stopped

The space heater must run as soon as the alternator stops. It is installed at the rear of the alternator. Its standard power is 500W with 220V or 250W with 110V on request.



**Caution : the power supply is present when the alternator has stopped.**

#### • Connection accessories

- 6-wire machines

Requirements for coupling (F):

- 3 links.

# LSA 52.3

## Low Voltage Alternators - 4 pole

### 5.4 - Exploded view, parts list and tightening torque

#### • Single-bearing

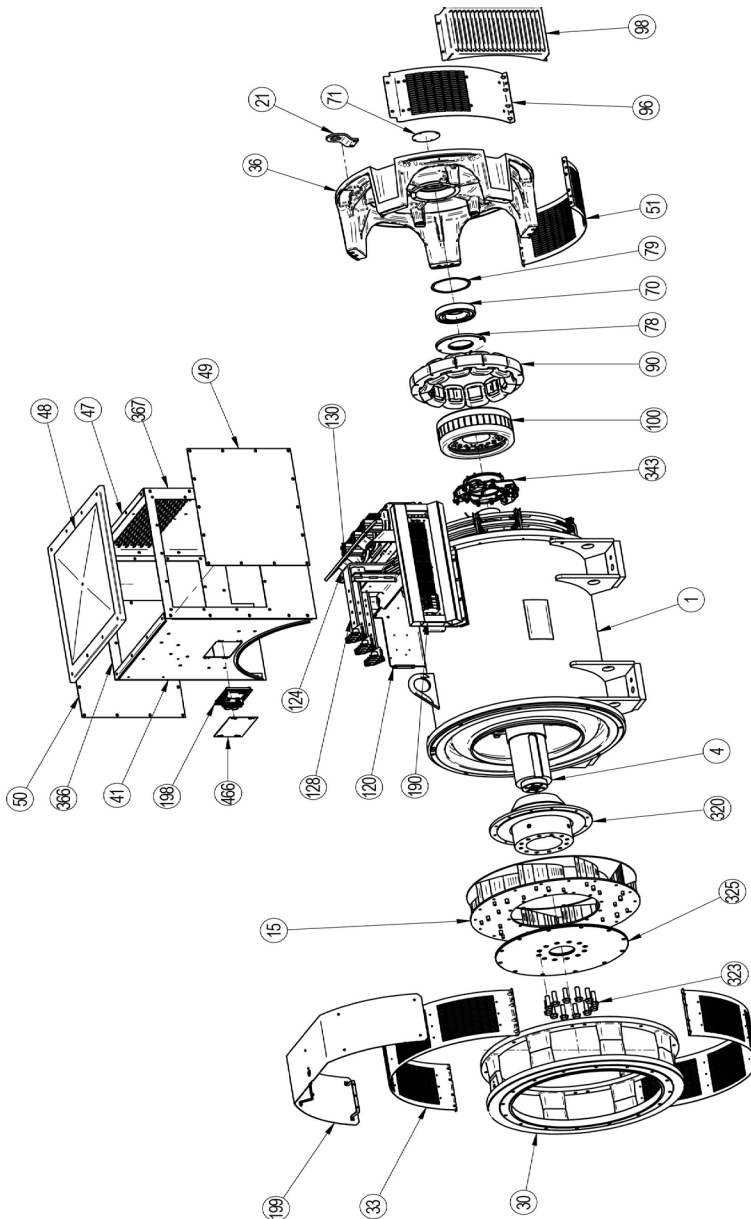

# LSA 52.3

## Low Voltage Alternators - 4 pole

### • Double bearing

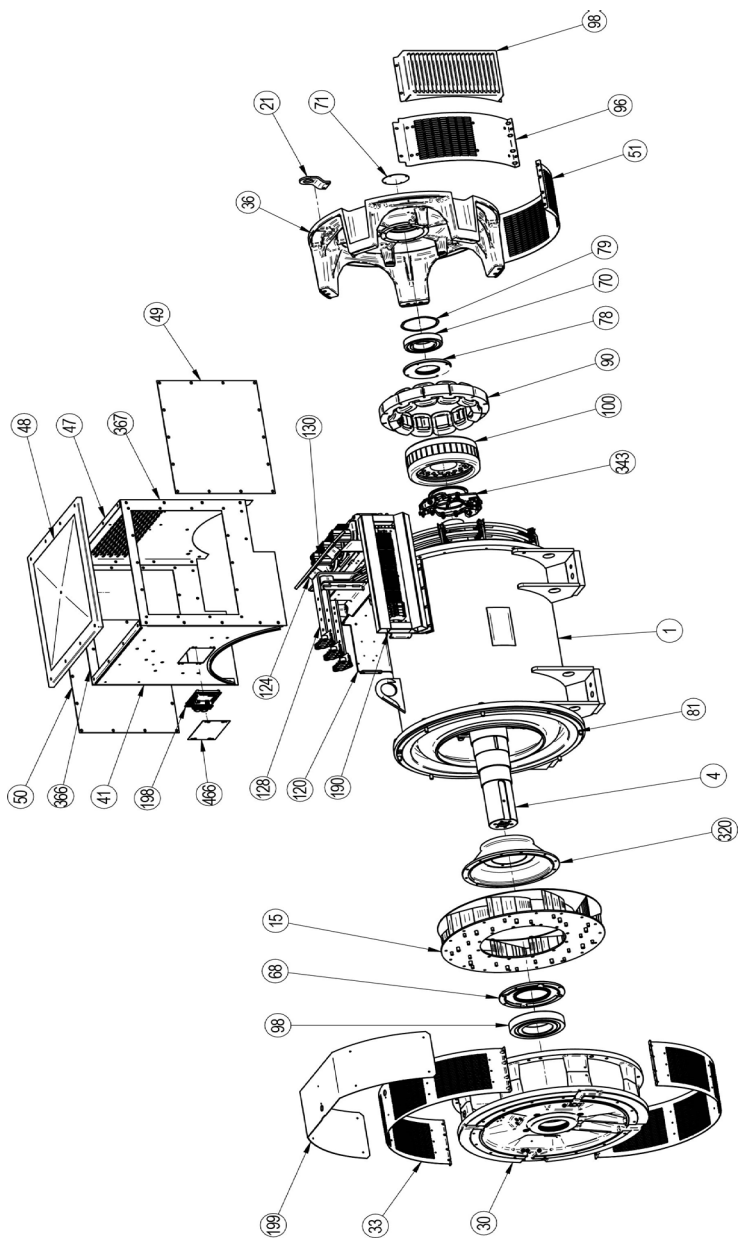

## LSA 52.3

### Low Voltage Alternators - 4 pole

Ref.	Qty	Description	Screw Ø	Torque N.m	Ref.	Qty	Description	Screw Ø	Torque N.m
1	1	Stator assembly	-	-	90	1	Exciter field	M8	20
4	1	Rotor assembly	-	-	96	2	Air inlet cover IP21	-	-
15	1	Fan	-	-	98	2	Air inlet cover IP23	-	-
21	1	Lifting ring	-	-	100	1	Exciter armature	-	-
30	1	Drive end shield	M12	69	120	1	Terminal support	-	-
33	1	Protective grille	M6	5	124	5	Terminals insulated supports	-	-
36	1	Exciter end shield	M12	69	128	3	Starting range	-	-
41	1	Cover front panel	M6	5	130	1	Neutral link	-	-
47	1	Terminal box rear lid	M6	5	190	1	Terminal block	-	-
48	1	Terminal box top lid	M6	5	198	1	Voltage regulator (AVR)	-	-
49-50	1	Inspection door	M6	5	199	1	Protective cover IP23	-	-
51	1	Air intake grille	M6	5	320	1	Coupling hub	-	-
60	1	DE bearing	-	-	322	3	Coupling disc	-	-
68	1	Inner bearing cap	-	-	323	8	Fixing screw	M20	340
70	1	NDE bearing	-	-	343	1	Diode bridge assembly	M6	4
71	1	Cover	-	-	366	1	Terminal box side lid	-	-
78	1	Inner bearing cap	-	-	367	1	Terminal box side lid with inspection door	-	-
79	1	Preloading wavy washer	-	-	466	1	AVR inspection door	-	-

## LSA 52.3

### Low Voltage Alternators - 4 pole

#### Disposal and recycling instructions

We are committed to limit the environmental impact of our activity. We continuously survey our production processes, material sourcing and products design to improve recyclability and diminish our footprint.

These instructions are for information purposes only. It is the user responsibility to comply with local legislation regarding product disposal and recycling.

#### Recyclable materials

Our alternators are mainly built out of iron, steel and copper materials, which can be reclaimed for recycling purposes.

These materials can be reclaimed through a combination of manual dismantling, mechanical separation and melting processes. Our technical support department can provide detailed directions on products dismounting upon request.

#### Waste & hazardous materials

The following components and materials need a special treatment and need to be separated from the alternator before the recycling process:

- electronic materials found in the terminal box, including the Automatic Voltage Regulator (198), Current Transformers (176), interference suppression module (199) and other semi-conductors.
- diode Bridge (343) and Surge suppressor (347), found on the alternator rotor.
- major plastic components, such as the terminal box structure on some products. These components are usually marked with plastic type information.

All materials listed above need special treatment to separate waste from reclaimable material and should be handed to specialized disposal companies.

The oil and grease from the lubrication system should be considered as a hazardous waste and has to be handled according to local legislation.

# LSA 52.3

## Low Voltage Alternators - 4 pole



# LSA 52.3

## Low Voltage Alternators - 4 pole

**Leroy-Somer**  
Electric Power Generation



### Declaration of EC compliance and incorporation

This Declaration applies to the generators designed to be incorporated into machines complying with the Machinery Directive Nr 2006/42/EC dated 17 May 2006.

MOTEURS LEROY-SOMER Boulevard Marcellin Leroy 16015 ANGOULEME FRANCE	MLS HOLICE STLO.SRO SLADKOVSKÉHO 43 772 04 OLOMOUC CZECH REPUBLIC	MOTEURS LEROY-SOMER 1, rue de la Burette Boite Postale 1517 45800 ST JEAN DE BRAYE FRANCE	DIVISION LEROY-SOMER STREET EMERSON Nr4 Parcul Industrial Tetarom 2 4000641 CLUJ NAPOCA ROMANIA
---	--	---	---

Declares hereby that the electric generators of the types:

LSA40 - LSA42.3 - LSA44.2 - LSA44.3 - LSA46.2 - LSA46.3 - LSA47.2 - LSA49.1 - LSA49.3 - LSA50.1 - LSA50.2 - LSA51.2 - LSA52.2 - LSA52.3 - LSA53.1 - LSA53 - LSA53.2 - LSA54 - LSA54.2 - TAL040 - TAL042 - TAL044, as well as their derivatives, manufactured by Leroy-Somer or on Leroy-Somer's behalf, comply with the following International Standards and Directive:

- EN and IEC 60034-1, 60034-5 and 60034-22
- ISO 8528-3 "Reciprocating internal combustion engine driven alternating current generating sets. Part 3. Alternating current generators for generating sets"
- Low Voltage Directive Nr 2014/35/UE dated 26 February 2014

Furthermore, these generators, designed in compliance with the Machine Directive Nr 2006/42, are therefore able to be incorporated into Electrical Gen-Sets complying with the following International Directives:

- Machinery Directive Nr 2006/42/EC dated 17 May 2006
- EMC Directive Nr 2014/30/UE dated 26 February 2014, as intrinsic levels of emissions and immunity are concerned

#### WARNING:

The here mentioned generators should not be commissioned until the corresponding Gen-Sets have been declared in compliance with the Directives Nr 2006/42/EC and 2014/30/UE, as well as with the other relevant Directives.

Leroy-Somer undertakes to transmit, in response to a reasoned request by the national authorities, relevant information on the generator.

**Technical Managers**  
J.P. CHARPENTIER - Y. MESSIN

4152 en - 2016.05 / k

The contractual EC Declaration of Conformity and Incorporation can be obtained from your contact on request.

# **LSA 52.3**

## **Low Voltage Alternators - 4 pole**

# Service & Support

Our worldwide service network of over 80 facilities is at your service.

This local presence is our guarantee for fast and efficient repair, support and maintenance services.

Trust your alternator maintenance and support to electric power generation experts. Our field personnel are 100% qualified and fully trained to operate in all environments and on all machine types.

We know alternators operation inside out, providing the best value service to optimize your cost of ownership.

Where we can help:



Contact us:

**Americas:** +1 (507) 625 4011

**Europe & International:** +33 238 609 908

**Asia Pacific:** +65 6263 6334

**China:** +86 591 88373036

**India:** +91 806 726 4867

✉ [service.epg@leroy-somer.com](mailto:service.epg@leroy-somer.com)



Scan the code or go to:  
[www.lrsr.co/support](http://www.lrsr.co/support)

**EMERSON. CONSIDER IT SOLVED.™**

[www.emerson.com/epg](http://www.emerson.com/epg)

**Leroy-Somer™**

